

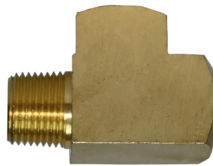

ROBO-FIT, INC.

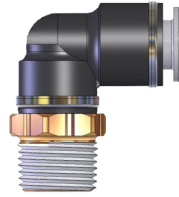

TRANSPORTATION PRODUCT CATALOG



Connecting Like Family

440-893-9878



WWW.ROBO-FIT.COM

**TABLE OF CONTENTS**

CATALOG SECTION	PAGE NUMBER
BRASS PIPE FITTINGS	2-9
BRASS HOSE BARB FITTINGS	10-16
BRASS PUSH-LOK HOSE BARB FITTINGS	17-21
NYLON AIR BRAKE DOT FITTINGS	22-26
BRASS PUSH-IN DOT FITTINGS	27-33
COMPOSITE PUSH-IN DOT FITTINGS	34-38
NYLON AIR BRAKE TUBING	39-40
AIR BRAKE HOSE ENDS	41-44
DRAIN & TRUCK VALVES	45-47
SELECTOR VALVES	48-50
PANEL MOUNT BALL VALVES	51-52
INDUSTRIAL BALL VALVES	53-54
CHECK VALVES	55-56
BRASS MINI BALL VALVES	57-58
PUSH BUTTON VALVES	59
STRAINER VALVES	60
PRODUCT WARRANTY	61
PRODUCT INDEX	62
PIPE THREAD SPECIFICATIONS	63
FITTING CONFIGURATION AND NUMBERING	64-65
PROPOSITION 65	66
SAE SPECIFICATIONS	67
FITTING ASSEMBLY REFERENCE CHART	68



BRASS PIPE FITTINGS

CONSTRUCTION	<ul style="list-style-type: none"> • CA360, CA345, CA3604, CA377 Brass 
APPLICATIONS	<ul style="list-style-type: none"> • Use with brass, copper or iron pipe 
RANGES	<ul style="list-style-type: none"> • Temperature Range: 65° to +250° F. • Pressure Range: Up to 1000 PSI 



Pipe Thread Assembly:

Straight Fittings:

1. Hand Tighten
2. 1/8" to 1/2": Wrench Tight 2 Full 360° Turns
1/2" & Above: 1 1/2" Full Turns

Shaped Fittings:

1. Hand Tighten
2. Wrench Tight 1" to 1 1/2" Full 360° Turns

**For NPTF Pipe Threads with Pre-Applied Sealant*

ORDERING INFORMATION

- Parts that include "F" in the part number, for example, 101AF-A, are supplied forgings.
- Parts that include "PBF" are supplied as low lead compliant fittings.
- Part number without the "PBF" distinction are NOT lead free compliant.
- Nomenclature Example:

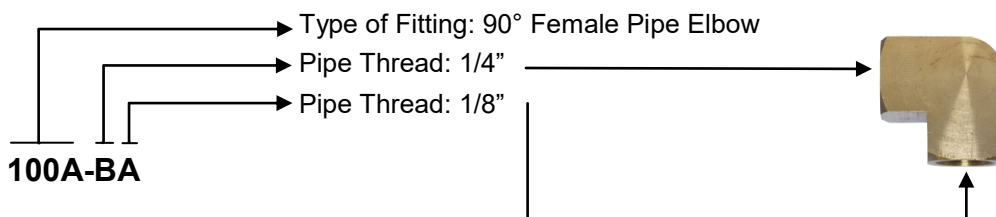

NOTES

- Non-stock items and special parts are available on a quotation basis.
- Configurations and dimensions are subject to change without notice.





Quality Matters!
Our Pipe Threads are made with the proper wall thickness and are made to dry-seal specifications.

⚠ WARNING: Products offered by Robo-Fit, Inc. can expose you to chemicals such as lead, a chemical which is known to the State of California to cause cancer, birth defects, or other reproductive harm. For more information go to www.P65Warnings.ca.gov

<p>100A 90° Female Elbow</p> 	<p>100-45A 45° Female Elbow</p> 	<p>101A Female Pipe Tee</p> 	<p>102A Female Cross Tee</p> 	<p>103A Female Coupling</p> 	<p>104A Ground Joint</p> 
<p>108A Pipe Cap</p> 	<p>109A (Cored) Square Head Plug</p> 	<p>109AS (Solid) Square Head Plug</p> 	<p>109CS Counter Sunk Plug</p> 	<p>110FB Face Bushing</p> 	<p>110A Hex Bushing</p> 
<p>111A Lock Nut</p> 	<p>112A Close Nipple</p> 	<p>113A Yellow Brass Nipple</p> 	<p>113RB Red Brass Nipple</p> 	<p>116A 90° Street Elbow</p> 	<p>116AL 90° Long Street Elbow</p> 
<p>116AM 90° Male Elbow</p> 	<p>117A Slotted Plug</p> 	<p>119A Reducer</p> 	<p>120A Adapter</p> 	<p>121A (Cored) Hex Head Plug</p> 	<p>121AS (Solid) Hex Head Plug</p> 
<p>122A Hex Nipple</p> 	<p>123A Hex Reducing Nipple</p> 	<p>124A 45° Street Elbow</p> 	<p>127A Street Tee</p> 	<p>127S Street Tee (FXMXM)</p> 	<p>T9 Branch Tee</p> 
<p>129A Bulkhead</p> 					

100A 90° ELBOW FPT TO FPT

PART NUMBER	PIPE THREAD	A	B
100A-A	1/8"	.59	.59
100AF-A	1/8"	.58	.58
100A-B	1/4"	.78	.78
100AF-B	1/4"	.72	.72
100A-BA	1/4" x 1/8"	.72	.72
100A-C	3/8"	.84	.84
100A-CB	3/8" x 1/4"	.84	.84
100AF-CB	3/8" x 1/4"	.81	.81
100A-D	1/2"	.84	.84
100AF-D	1/2"	1.00	1.00
100A-DC	1/2" x 3/8"	1.00	1.00
100AF-DC	1/2" x 3/8"	1.00	1.00
100A-E	3/4"	1.18	1.18
100AF-E	3/4"	1.10	1.10

REF SAE 130238

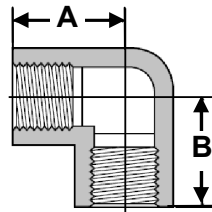

Forged Style



Barstock Style

100-45A ELBOW 45° FPT TO FPT

PART NUMBER	PIPE THREAD	A	B
100-45A-A	1/8"	.46	.46
100-45A-B	1/4"	.64	.64
100-45A-C	3/8"	.61	.61
100-45A-D	1/2"	.91	.91
100-45A-E	3/4"	1.00	1.00

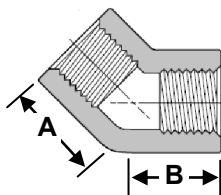

Barstock Style

101A TEE FPT ALL ENDS

PART NUMBER	PIPE THREAD	A	B
101A-A	1/8"	.56	.56
101AF-A	1/8"	.56	.56
101A-B	1/4"	.75	.75
101AF-B	1/4"	.72	.72
101A-BBA	1/4" x 1/4" x 1/8"	.69	.69
101A-C	3/8"	.84	.84
101AF-C	3/8"	.84	.84
101A-CCB	3/8" x 3/8" x 1/4"	.80	.85
101A-D	1/2"	1.09	1.09
101AF-D	1/2"	.98	.98
100A-DDC	1/2" x 1/2" x 3/8"	1.00	1.00
101A-E	3/4"	1.18	1.18
101AF-E	3/4"	1.13	1.13

REF SAE 130438

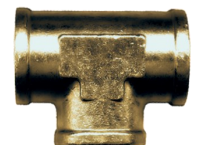
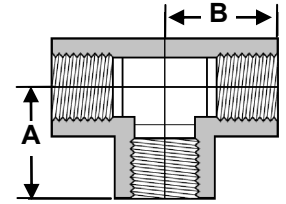

Forged Style



Barstock Style

102A CROSS FPT ALL ENDS

PART NUMBER	PIPE THREAD	A
102A-A	1/8"	.65
102AF-A	1/8"	.52
102A-B	1/4"	.78
102AF-B	1/4"	.66
102A-C	3/8"	.98
102AF-C	3/8"	.82
102AF-D	1/2"	1.08
102AF-E	3/4"	1.18

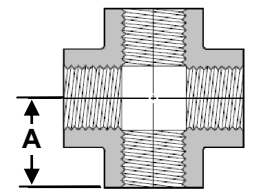

Forged Style



Barstock Style

103A COUPLING FPT TO FPT

PART NUMBER	PIPE THREAD	A	HEX
103AH-A	1/8"	.75	9/16"
103AH-B	1/4"	1.12	3/4"
103AH-C	3/8"	1.12	7/8"
103AH-D	1/2"	1.50	1-1/16"
103AH-E	3/4"	1.53	1-3/8"

REF SAE 130138

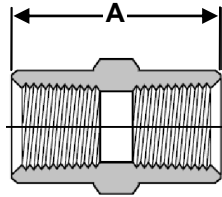

104A GROUND JOINT UNION FPT TO FPT

PART NUMBER	PIPE THREAD	A	HEX
104A-A	1/8"	1.19	9/16"
104A-B	1/4"	1.22	11/16"
104A-C	3/8"	1.72	11/16"
104A-D	1/2"	1.78	15/16"
104A-E	3/4"	1.88	1-1/4"

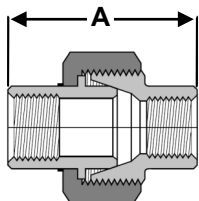

108A PIPE CAP

PART NUMBER	PIPE THREAD	A	HEX
108A-A	1/8"	.47	9/16"
108A-B	1/4"	.59	11/16"
108A-C	3/8"	.69	13/16"
108A-D	1/2"	.78	15/16"
108A-E	3/4"	.94	1-1/4"

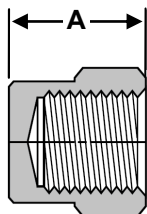

109A SQUARE HEAD PLUG CORED

PART NUMBER	PIPE THREAD	A
109A-A	1/8"	.58
109A-B	1/4"	.70
109A-C	3/8"	.73
109A-D	1/2"	.93
109A-E	3/4"	1.00
109A-F	1"	1.20

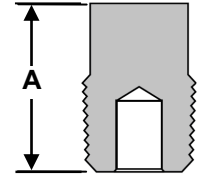

109AS SQUARE HEAD PLUG SOLID

PART NUMBER	PIPE THREAD	A
109AS-D	1/2"	.93
109AS-E	3/4"	1.00
109AS-F	1"	1.20



109CS COUNTER-SUNK PLUG

PART NUMBER	PIPE THREAD	A
109CS-A	1/8"	.30
109CS-B	1/4"	.45
109CS-C	3/8"	.45
109CS-D	1/2"	.60
109CS-E	3/4"	.55

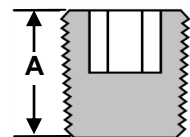

110FB FACE BUSHING

PART NUMBER	PIPE THREAD	A
110FB-CB	3/8" x 1/4"	.50
110FB-DB	1/2" x 1/4"	.53
110FB-DC	1/2" x 3/8"	.53
110FB-ED	3/4" x 1/2"	.55

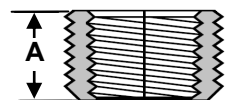

110A HEX BUSHING

PART NUMBER	PIPE THREAD	A	HEX
110A-BA	1/4" x 1/8"	.62	9/16"
110AH-BA	1/4" x 1/8"	.75	9/16"
110A-CA	3/8" x 1/8"	.69	11/16"
110AH-CA	3/8" x 1/8"	.75	11/16"
110A-CB	3/8" x 1/4"	.69	11/16"
110AH-CB	3/8" x 1/4"	.75	3/4"
110A-DA	1/2" x 1/8"	.81	13/16"
110AH-DA	1/2" x 1/8"	1.00	7/8"
110A-DB	1/2" x 1/4"	.81	13/16"
110AH-DB	1/2" x 1/4"	1.00	7/8"
110A-DC	1/2" x 3/8"	.81	13/16"
110AH-DC	1/2" x 3/8"	1.00	7/8"
110A-EA	3/4" x 1/8"	.94	1-1/16"
110AH-EA	3/4" x 1/8"	1.00	1-1/8"
110A-EB	3/4" x 1/4"	.94	1-1/16"
110AH-EB	3/4" x 1/4"	1.00	1-1/8"
110A-EC	3/4" x 3/8"	.94	1-1/16"
110AH-EC	3/4" x 3/8"	1.00	1-1/8"
110A-ED	3/4" x 1/2"	.94	1-1/16"
110AH-ED	3/4" x 1/2"	1.00	1-1/8"
110A-FB	1" x 1/4"	1.12	1-3/8"
110A-FC	1" x 3/8"	1.12	1-3/8"
110A-FD	1" x 1/2"	1.12	1-3/8"
110A-FE	1" x 3/4"	1.12	1-3/8"

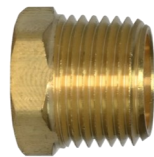
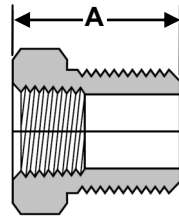

112A CLOSE NIPPLE

PART NUMBER	PIPE THREAD	A
112A-A	1/8"	.75
112A-B	1/4"	.88
112A-C	3/8"	1.00
112A-D	1/2"	1.12
112A-E	3/4"	1.31
112A-F	1"	1.31

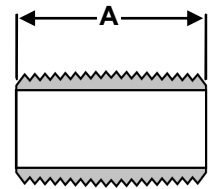

113A LONG NIPPLE (YELLOW BRASS)

PART NUMBER	PIPE THREAD	A
113A-A15	1/8"	1-1/2"
113A-B15	1/4"	1-1/2"
113A-C15	3/8"	1-1/2"
113A-D15	1/2"	1-1/2"
113A-E15	3/4"	1-1/2"
113A-A2	1/8"	2
113A-B2	1/4"	2
113A-C2	3/8"	2
113A-D2	1/2"	2
113A-E3	3/4"	2

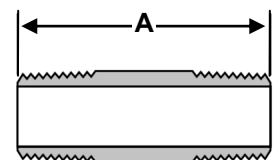

REF SAE 130140 (AH Style)

111A LOCK NUT

PART NUMBER	PIPE THREAD	A	HEX
111A-A	1/8"	.19	11/16"
111A-B	1/4"	.25	7/8"
111A-C	3/8"	.31	1"
111A-D	1/2"	.25	1-1/8"
111A-E	3/4"	.33	1-1/2"

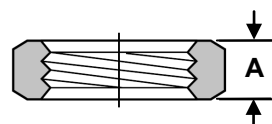

113RB LONG NIPPLE (RED BRASS)

PART NUMBER	PIPE THREAD	A
113RB-A25	1/8"	2-1/2"
113RB-B25	1/4"	2-1/2"
113RB-C25	3/8"	2-1/2"
113RB-D25	1/2"	2-1/2"
113RB-E25	3/4"	2-1/2"
113RB-A3	1/8"	3"
113RB-B3	1/4"	3"
113RB-C3	3/8"	3"
113RB-D3	1/2"	3"
113RB-E3	3/4"	3"
113RB-A35	1/8"	3-1/2"
113RB-B35	1/4"	3-1/2"
113RB-C35	3/8"	3-1/2"
113RB-D35	1/2"	3-1/2"
113RB-E35	3/4"	3-1/2"
113RB-A4	1/8"	4"
113RB-B4	1/4"	4"
113RB-C4	3/8"	4"
113RB-D4	1/2"	4"
113RB-E4	3/4"	4"
113RB-A45	1/8"	4-1/2"
113RB-B45	1/4"	4-1/2"
113RB-C45	3/8"	4-1/2"
113RB-D45	1/2"	4-1/2"
113RB-E45	3/4"	4-1/2"
113RB-A5	1/8"	5"
113RB-B5	1/4"	5"
113RB-C5	3/8"	5"
113RB-D5	1/2"	5"
113RB-E5	3/4"	5"
113RB-A55	1/8"	5-1/2"
113RB-B55	1/4"	5-1/2"
113RB-C55	3/8"	5-1/2"
113RB-D55	1/2"	5-1/2"
113RB-E55	3/4"	5-1/2"
113RB-A6	1/8"	6"
113RB-B6	1/4"	6"
113RB-C6	3/8"	6"
113RB-D6	1/2"	6"
113RB-E6	3/4"	6"

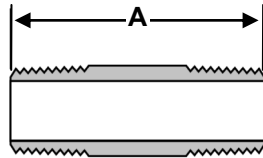

116A 90° STREET ELBOW

PART NUMBER	PIPE THREAD	A	B
116A-A	1/8"	.62	.35
116AF-A	1/8"	.81	.56
116A-A-BK	1/8"	.62	.48
116A-B	1/4"	.78	.43
116AF-B	1/4"	.86	.44
116A-B-BK	1/4"	.91	.72
116A-C	3/8"	1.00	.89
116AF-C	3/8"	.98	.68
116A-C-BK	3/8"	.97	.78
116A-D	1/2"	1.25	1.03
116AF-D	1/2"	1.43	.94
116A-D-BK	1/2"	1.25	1.03
116A-E	3/4"	1.40	1.08
116AF-E	3/4"	1.50	.91
116A-E-BK	3/4"	1.39	1.10

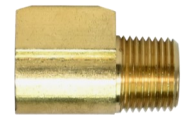
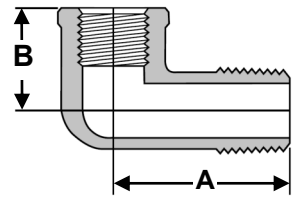

Mailbox Style

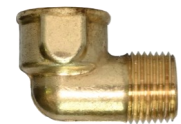

Forged Style

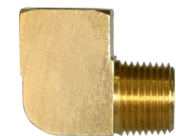

Block Style

116AL STREET ELBOW LONG PATTERN

PART NUMBER	PIPE THREAD	A	B
116AL-A	1/8"	.80	.46
116AL-B	1/4"	1.10	.68
116AL-C	3/8"	1.29	.95

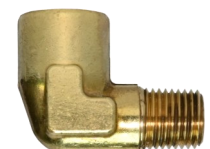
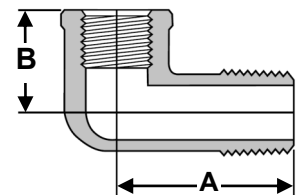

116AM MALE ELBOW

PART NUMBER	PIPE THREAD	A	B
116AM-A	1/8"	.69	.69
116AMF-A	1/8"	.71	.71
116AM-B	1/4"	.88	.88
116AMF-B	1/4"	1.09	1.09
116AMF-BA	1/4" x 1/8"	.77	.95
116AM-C	3/8"	1.06	1.06
116AM-CB	3/8" x 1/4"	.92	.92
116AM-D	1/2"	1.40	1.40
116AMF-D	1/2"	1.41	1.41
116AM-DC	1/2" x 3/8"	1.02	1.12

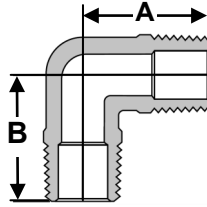

120A ADAPTER FPT TO MPT

PART NUMBER	PIPE THREAD	A	Hex
120AH-AA	1/8" x 1/8"	.87	9/16"
120AH-BA	1/4" x 1/8"	1.06	3/4"
120AH-BB	1/4" x 1/4"	1.06	3/4"
120A-CA	3/8" x 1/8"	1.00	3/4"
120AH-CB	3/8" x 1/4"	1.25	7/8"
120AH-CC	3/8" x 3/8"	1.25	1.06
120AH-DB	1/2" x 1/4"	1.46	1-1/16"
120AH-DC	1/2" x 3/8"	1.46	1-1/16"
120AH-DD	1/2" x 1/2"	1.65	1-1/16"
120A-ED	3/4" x 1/2"	1.22	1-1/4"

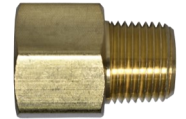
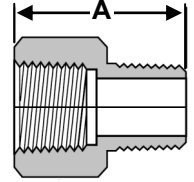

117A SLOTTED PLUG

PART NUMBER	PIPE THREAD	A
117A-A	1/8"	.30
117A-B	1/4"	.45
117A-C	3/8"	.45

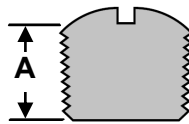

121A HEX HEAD PLUG CORED

PART NUMBER	PIPE THREAD	A	Hex
121A-A	1/8"	.56	7/16"
121A-B	1/4"	.62	9/16"
121A-C	3/8"	.72	11/16"
121A-D	1/2"	.81	7/8"
121A-E	3/4"	.84	1-1/16"
121A-F	1"	1.12	1-3/16"

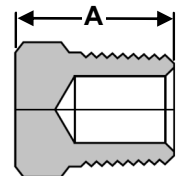

119A REDUCER FPT TO FPT

PART NUMBER	PIPE THREAD	A	Hex
119AH-BA	1/4" x 1/8"	.96	3/4"
119A-CA	3/8" x 1/8"	1.00	3/4"
119AH-CB	3/8" x 1/4"	1.16	7/8"
119A-DA	1/2" x 1/8"	1.19	15/16"
119AH-DB	1/2" x 1/4"	1.38	1-1/16"
119AH-DC	1/2" x 3/8"	1.38	1-1/16"
119A-ED	3/4" x 1/2"	1.19	1-1/4"

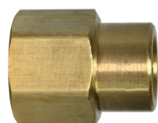
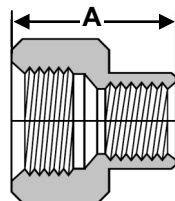

121AS HEX HEAD PLUG SOLID

PART NUMBER	PIPE THREAD	A	Hex
121AS-A	1/8"	.56	7/16"
121AS-B	1/4"	.62	9/16"
121AS-C	3/8"	.72	11/16"
121AS-D	1/2"	.81	7/8"
121AS-E	3/4"	.94	1-1/16"

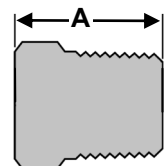

REF SAE 130138 (AH Style)

122A HEX NIPPLE

PART NUMBER	PIPE THREAD	A	Hex
122AH-A	1/8"	.97	7/16"
122AH-B	1/4"	1.37	9/16"
122AH-C	3/8"	1.40	11/16"
122AH-D	1/2"	1.81	7/8"
122AH-E	3/4"	1.96	1-1/8"

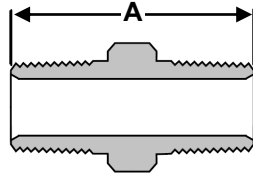

REF SAE 130137

123A HEX REDUCING NIPPLE

PART NUMBER	PIPE THREAD	A	Hex
123AH-BA	1/4" x 1/8"	1.18	9/16"
123AH-CA	3/8" x 1/8"	1.21	11/16"
123AH-CB	3/8" x 1/4"	1.40	11/16"
123AH-DB	1/2" x 1/4"	1.62	7/8"
123AH-DC	1/2" x 3/8"	1.62	7/8"
123A-ED	3/4" x 1/2"	1.50	1-1/16"

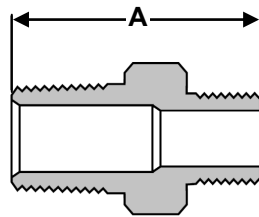

REF SAE 130137 (AH Style)

124A STREET ELBOW 45°

PART NUMBER	PIPE THREAD	A	B
124A-A	1/8"	.38	.50
124A-B	1/4"	.74	.55
124A-C	3/8"	.78	.56
124A-D	1/2"	.98	.74

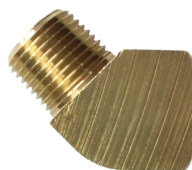
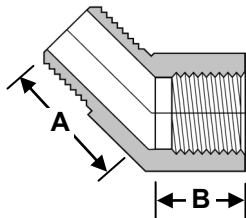

REF SAE 130339

127A STREET TEE FPT TO MPT TO FPT

PART NUMBER	PIPE THREAD	A	B
127A-A	1/8"	.55	.56
127A-B	1/4"	.78	.91
127A-C	3/8"	.84	1.03
127A-D	1/2"	1.16	1.16

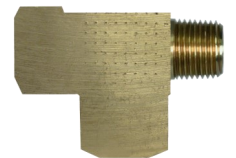
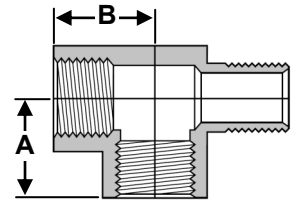

REF SAE 130339

T9 BRANCH TEE FPT TO FPT TO MPT

PART NUMBER	PIPE THREAD	A	B
T9-222	1/8"	.62	.31
T9-444	1/4"	1.50	.75
T9-666	3/8"	1.60	.80
T9-888	1/2"	2.14	1.07

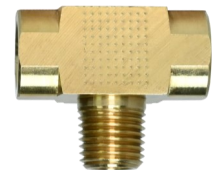
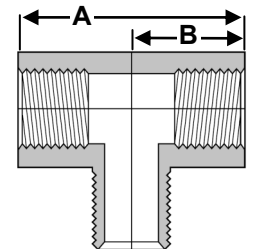

REF SAE 130425

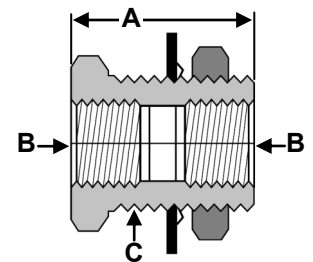

129A BULKHEAD ADAPTER

PART NUMBER	A	B	C
129A-A	1.50	1/8" FPT	5/8-18
129AS-B	.92	1/4" FPT	3/4-16
129A-B	1.50	1/4" FPT	3/4-16
129A-C	1.32	3/8" FPT	1-14
129A-D	1.50	1/2" FPT	1 1/8-14
129A-E	1.50	3/4" FPT	1-5/16-12



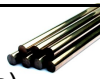

BRASS HOSE BARB FITTINGS

CONSTRUCTION	<ul style="list-style-type: none"> • CA360/CA3604 Brass (Straights) • CA360/CA3604/CA377 Brass (Shapes) 
APPLICATIONS	<ul style="list-style-type: none"> • Use with thermoplastic or rubber hose and tubing. For use with a hose clamp or crimped type fitting. • Temperature Range: -40° to 160° F.
RANGES	<ul style="list-style-type: none"> • Pressure Range: Up to 150 PSI 



Pipe Thread Assembly:

Straight Fittings:

1. Hand Tighten
2. 1/8" to 1/2": Wrench Tight 2 Full 360° Turns
1/2" & Above: 1 1/2" Full Turns

Shaped Fittings:

1. Hand Tighten
2. Wrench Tight 1" to 1 1/2" Full 360° Turns

**For NPTF Pipe Threads with Pre-Applied Sealant*

ORDERING INFORMATION

- Parts that include "PBF" are supplied as low lead compliant fittings.
- Part numbers without the "PBF" distinction are NOT lead free compliant.
- Nomenclature Example:

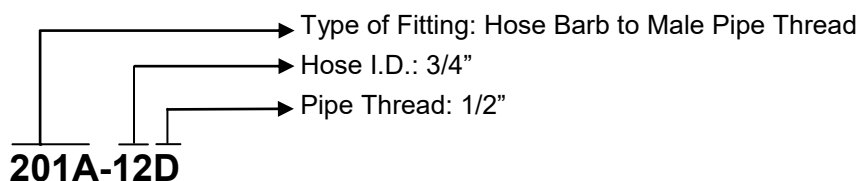

NOTES

- Non-stock items and special parts are available on a quotation basis.
- Configurations and dimensions are subject to change without notice.

TYPES OF BARBS

Multi-Barb



Beaded Hose Barb



Beaded Barbs are popular with 1/2" Hose Sizes and above.

⚠ WARNING: Products offered by Robo-Fit, Inc. can expose you to chemicals such as lead, a chemical which is known to the State of California to cause cancer, birth defects, or other reproductive harm. For more information go to www.P65Warnings.ca.gov

<p>201A Hose Barb to MPT</p> 	<p>201A-SV Hose Barb to MPT Swivel</p> 	<p>201AB Beaded Hose Barb to MPT</p> 	<p>201BF Hose to Male Flare</p> 
<p>209A Hose Barb to FPT</p> 	<p>209A-SV Hose Barb to FPT Swivel</p> 	<p>209AS Hose Barb to Swivel Ball End</p> 	<p>122AS Swivel Ball Adapter</p> 
<p>209ASF Hose Barb to FM Flare Swivel</p> 	<p>HE1 90° Elbow, Hose to MPT</p> 	<p>HE1-BK 90° Elbow, Hose to MPT</p> 	<p>HE1-FM 90° Elbow, Hose to FPT</p> 
<p>269HB 90° Elbow, Beaded Barb to MPT</p> 	<p>HE1-45 45° Elbow, Hose to MPT</p> 	<p>HM Hose Mender</p> 	<p>HM-90 90° Elbow, Hose to Hose</p> 
<p>HBT2 Hose Barb Tee</p> 	<p>122RWA/122LWA Welding Adapter to Hand Thread</p> 	<p>209RWA/LWA Welding Adapter, Hose x 9/16-18</p> 	<p>BF Hose Crimp On Ferrule</p> 

201A HOSE BARB TO MPT

PART NUMBER	HOSE ID	MPT	A	B	HEX
201A-3A	3/16"	1/8"-27	.69	1.25	1/2"
201A-3B	3/16"	1/4"-18	.69	1.48	9/16"
201A-4A	1/4"	1/8"-27	.97	1.53	1/2"
201A-4B	1/4"	1/4"-18	.97	1.76	9/16"
201A-4C	1/4"	3/8"-18	.97	1.76	11/16"
201A-5A	5/16"	1/8"-27	.97	1.53	1/2"
201A-5B	5/16"	1/4"-18	.97	1.76	9/16"
201A-5C	5/16"	3/8"-18	.97	1.76	11/16"
201A-6A	3/8"	1/8"-27	.97	1.53	1/2"
201A-6B	3/8"	1/4"-18	.97	1.76	9/16"
201A-6C	3/8"	3/8"-18	.97	1.76	11/16"
201A-6D	3/8"	1/2"-14	.97	1.97	7/8"
201A-8B	1/2"	1/4"-18	.97	1.76	9/16"
201A-8C	1/2"	3/8"-18	.97	1.76	11/16"
201A-8D	1/2"	1/2"-14	.97	1.97	7/8"
201A-8E	1/2"	3/4"-14	.97	1.97	1 1/16"
201A-10C	5/8"	3/8"-18	.97	1.76	11/16"
201A-10D	5/8"	1/2"-14	.97	1.97	7/8"
201A-10E	5/8"	3/4"-14	.97	1.97	1 1/16"
201A-12D	3/4"	1/2"-14	.97	1.97	7/8"
201A-12E	3/4"	3/4"-14	.97	1.97	1 1/16"
201A-12F	3/4"	1"-11 1/2	1.19	2.53	1 3/8"
201A-16E	1"	3/4"-14	1.19	2.19	1 1/16"
201A-16F	1"	1"-11 1/2	1.19	2.53	1 3/8"
201A-20E	1 1/4"	3/4"-14	1.19	2.28	1 3/8"
201A-20F	1 1/4"	1"-11 1/2	1.19	2.53	1 3/8"

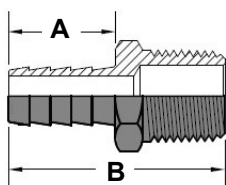

201AB BEADED HOSE BARB TO MPT

PART NUMBER	HOSE ID	MPT	A	B	HEX
201AB-4A	1/4"	1/8"-27	.62	1.18	1/2"
201AB-4B	1/4"	1/4"-18	.62	1.41	9/16"
201AB-5A	5/16"	1/8"-27	.62	1.18	1/2"
201AB-5B	5/16"	1/4"-18	.62	1.41	9/16"
201AB-6A	3/8"	1/8"-27	.87	1.43	1/2"
201AB-6B	3/8"	1/4"-18	.87	1.67	9/16"
201AB-6C	3/8"	3/8"-18	.87	1.67	11/16"
201AB-8C	1/2"	3/8"-18	.87	1.67	11/16"
201AB-8D	1/2"	1/2"-14	.87	1.88	7/8"
201AB-10D	5/8"	1/2"-14	.87	1.88	7/8"
201AB-10E	5/8"	3/4"-14	.87	1.88	1 1/16"
201AB-12D	3/4"	1/2"-14	.87	1.88	7/8"
201AB-12E	3/4"	3/4"-14	.87	1.88	1 1/16"

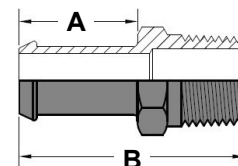

201BF HOSE BARB TO MALE FLARE

PART NUMBER	HOSE ID	FLARE THREAD	A	B	HEX
201BF-33	3/16"	3/16"	1.50	.75	7/16"
201BF-44	1/4"	1/4"	1.75	.75	1/2"
201BF-45	1/4"	5/16"	1.75	.75	1/2"
201BF-46	1/4"	3/8"	1.84	.87	5/8"
201BF-55	5/16"	5/16"	1.84	.87	5/8"
201BF-66	3/8"	3/8"	1.84	.87	5/8"
201BF-68	3/8"	1/2"	1.97	.97	3/4"
201BF-88	1/2"	1/2"	1.95	.92	7/8"

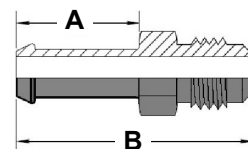

201A-SV HOSE BARB TO MPT SWIVEL

PART NUMBER	HOSE ID	MPT	A	B	HEX
201A-3A-SV	3/16"	1/8"-27	.69	1.48	1/2"
201A-4A-SV	1/4"	1/8"-27	.97	1.76	1/2"
201A-4B-SV	1/4"	1/4"-18	.97	1.80	9/16"
201A-5B-SV	5/16"	1/4"-18	.97	1.80	9/16"
201A-6B-SV	3/8"	1/4"-18	.97	1.80	9/16"
201A-6C-SV	3/8"	3/8"-18	.97	1.80	3/4"
201A-6D-SV	3/8"	1/2"-14	.97	2.00	7/8"
201A-8C-SV	1/2"	3/8"-18	.97	1.80	3/4"
201A-8D-SV	1/2"	1/2"-14	.97	2.00	7/8"
201A-12E-SV	3/4"	3/4"-14	.97	2.15	1 1/8"

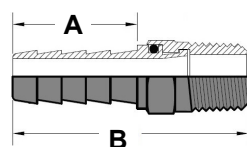

209A HOSE BARB TO FPT

PART NUMBER	HOSE ID	FPT	A	B	HEX
209A-4A	1/4"	1/8"-27	.97	1.45	1/2"
209A-4B	1/4"	1/4"-18	.97	1.61	5/8"
209A-4C	1/4"	3/8"-18	.97	1.63	3/4"
209A-5A	5/16"	1/8"-27	.97	1.45	1/2"
209A-5B	5/16"	1/4"-18	.97	1.61	5/8"
209A-5C	5/16"	3/8"-18	.97	1.63	3/4"
209A-6A	3/8"	1/8"-27	.97	1.45	1/2"
209A-6B	3/8"	1/4"-18	.97	1.61	5/8"
209A-6C	3/8"	3/8"-18	.97	1.63	3/4"
209A-6D	3/8"	1/2"-14	.97	1.77	15/16"
209A-8B	1/2"	1/4"-18	.97	1.61	5/8"
209A-8C	1/2"	3/8"-18	.97	1.63	3/4"
209A-8D	1/2"	1/2"-14	.97	1.77	15/16"
209A-10C	5/8"	3/8"-18	.97	1.63	3/4"
209A-10D	5/8"	1/2"-14	.97	1.77	15/16"
209A-12D	3/4"	1/2"-14	.97	1.77	15/16"
209A-12E	3/4"	3/4"-14	.97	1.77	1 1/8"
209A-16E	1"	3/4"-14	.97	1.77	1 1/8"

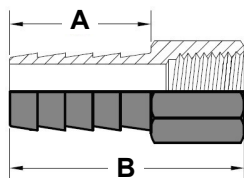

209AS HOSE BARB TO SWIVEL BALL END

PART NUMBER	HOSE ID	FPT	A	B	HEX
209AS-4B	1/4"	1/4"-18	.97	1.56	5/8"
209AS-5B	5/16"	1/4"-18	.97	1.56	5/8"
209AS-6B	3/8"	1/4"-18	.97	1.56	5/8"
209AS-6C	3/8"	3/8"-18	.97	1.62	9/16"
209AS-8C	1/2"	3/8"-18	.97	1.62	3/4"
209AS-8D	1/2"	1/2"-18	.97	1.73	15/16"
209AS-12E	3/4"	3/4"-14	.97	1.73	1 1/8"

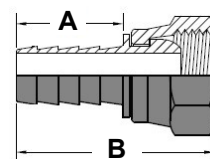

122AS SWIVEL BALL ADAPTER

PART NUMBER	MALE N.P.S.M.	MPT	A	HEX
122AS-4A	1/4"	1/8"-27	.91	9/16"
122AS-4B	1/4"	1/4"-18	1.02	9/16"
122AS-6B	3/8"	1/4"-18	1.02	11/16"
122AS-6C	3/8"	3/8"-18	1.09	11/16"
122AS-8C	1/2"	3/8"-18	1.19	27/32"
122AS-8D	1/2"	1/2"-14	1.39	27/32"

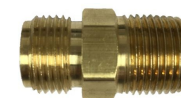
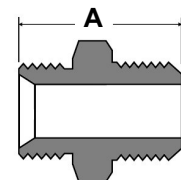

209A-SV HOSE BARB TO FPT SWIVEL

PART NUMBER	HOSE ID	FPT	A	B	HEX
209A-3A-SV	3/16"	1/8"-27	.69	1.45	1/2"
209A-4A-SV	1/4"	1/8"-27	.97	1.73	1/2"
209A-4B-SV	1/4"	1/4"-18	.97	1.80	5/8"
209A-5B-SV	5/16"	1/4"-18	.97	1.80	5/8"
209A-6B-SV	3/8"	1/4"-18	.97	1.80	5/8"
209A-6C-SV	3/8"	3/8"-18	.97	1.82	3/4"
209A-6D-SV	3/8"	1/2"-14	.97	1.86	15/16"
209A-8C-SV	1/2"	3/8"-18	.97	1.82	3/4"
209A-8D-SV	1/2"	1/2"-14	.97	1.86	15/16"

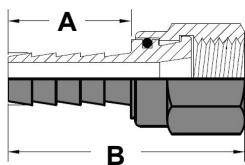

209ASF HOSE BARB TO FEMALE FLARE SW

PART NUMBER	HOSE ID	FLARE THREAD	A	HEX
209ASF-44	1/4"	7/16"-20	.97	9/16"
209ASF-45	1/4"	1/2"-20	.97	5/8"
209ASF-55	5/16"	1/2"-20	.97	5/8"
209ASF-68	3/8"	3/4"-16	.97	7/8"
209ASF-88	1/2"	3/4"-16	.97	7/8"
209ASF-810	1/2"	7/8"-14	.97	1"
209ASF-1010	5/8"	7/8"-14	.97	1"
209ASF-1210	3/4"	7/8"-14	.97	1"

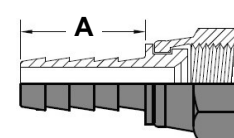

*Female Flare is a dual angle seat, accepting both 37°/45°

209ASF-45° HOSE BARB TO FEMALE FLARE SWIVEL

PART NUMBER	HOSE ID	FLARE THREAD	A	HEX
209ASF-46-45°	1/4"	5/8"-18	.97	3/4"
209ASF-56-45°	5/16"	5/8"-18	.97	3/4"
209ASF-66-45°	3/8"	5/8"-18	.97	3/4"
209ASF-1212-45°	3/4"	1 1/16"-14	.97	1 1/4"

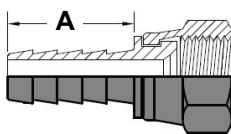

*Flare accepts 45° mating part only

209ASF-37° HOSE BARB TO FEMALE FLARE SWIVEL

PART NUMBER	HOSE ID	FLARE THREAD	A	HEX
209ASF-46-37°	1/4"	9/16"-18	.97	11/16"
209ASF-56-37°	5/16"	9/16"-18	.97	11/16"
209ASF-66-37°	3/8"	9/16"-18	.97	11/16"
209ASF-1212-37°	3/4"	1 1/16"-12	.97	1 1/4"

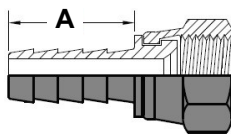

*Flare accepts 37° mating part only

HE1 90° ELBOW, HOSE TO MPT

PART NUMBER	HOSE ID	MPT	A
HE1-4A	1/4"	1/8"-27	1.00
HE1-4B	1/4"	1/4"-18	1.00
HE1-4C	1/4"	3/8"-18	1.08
HE1-5A	5/16"	1/8"-27	1.01
HE1-5B	5/16"	1/4"-18	1.01
HE1-5C	5/16"	3/8"-18	1.09
HE1-6A	3/8"	1/8"-27	1.01
HE1-6B	3/8"	1/4"-18	1.04
HE1-6C	3/8"	3/8"-18	1.08
HE1-6D	3/8"	1/2"-14	1.12
HE1-8B	1/2"	1/4"-18	1.08
HE1-8C	1/2"	3/8"-18	1.08
HE1-8D	1/2"	1/2"-14	1.16
HE1-10C	5/8"	3/8"-18	1.13
HE1-10D	5/8"	1/2"-14	1.21

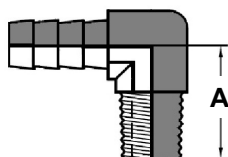

*Forged Style



*Barstock Style

HE1-FM 90° ELBOW, HOSE TO MPT

PART NUMBER	HOSE ID	FPT	A	B
HE1-4A-FM	1/4"	1/8"-27	1.05	.79
HE1-4B-FM	1/4"	1/4"-18	1.14	.79
HE1-6B-FM	5/16"	1/8"-27	1.14	.79
HE1-6C-FM	5/16"	1/4"-18	1.22	.79
HE1-8B-FM	3/8"	1/8"-27	1.17	.87
HE1-8C-FM	3/8"	1/4"-18	1.24	.89
HE1-8D-FM	3/8"	3/8"-18	1.29	.79
HE1-12E-FM	1/2"	3/8"-18	1.52	.97

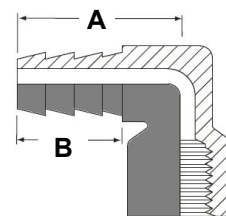

269HB 90° ELBOW, BEADED BARB TO MPT

PART NUMBER	HOSE ID	MPT	A	B	C
269HB-66	3/8"	3/8"-18	1.19	.78	.88
269HB-84	1/2"	1/4"-18	1.16	.78	.99
269HB-86	1/2"	3/8"-18	1.16	.78	1.08
269HB-8-8	1/2"	1/2"-14	1.28	.78	1.25
269HB-104	5/8"	1/4"-18	1.13	.78	.99
269HB-106	5/8"	3/8"-18	1.16	.78	.99
269HB-108	5/8"	1/2"-14	1.28	.78	1.25
269HB-128	3/4"	1/2"-14	1.28	.78	1.25
269HB-1212	3/4"	3/4"-14	1.33	.78	1.27

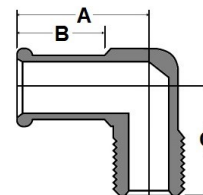

HE1-45 45° ELBOW, HOSE TO MPT

PART NUMBER	HOSE ID	MPT
HE1-45-4A	1/4"	1/8"-27
HE1-45-5A	5/16"	1/8"-27
HE1-45-5B	5/16"	1/4"-18
HE1-45-6A	3/8"	1/8"-27
HE1-45-6B	3/8"	1/4"-18
HE1-45-6C	3/8"	3/8"-18
HE1-45-8B	1/2"	1/4"-18
HE1-45-8C	1/2"	3/8"-18
HE1-45-10C	5/8"	3/8"-18



HM HOSE MENDER

PART NUMBER	HOSE ID	A
HM-2	1/8"	1.09
HM-3	3/16"	1.65
HM-4	1/4"	2.00
HM-5	5/16"	2.00
HM-6	3/8"	2.00
HM-8	1/2"	2.00
HM-10	5/8"	2.00
HM-12	3/4"	2.00
HM-16	1"	2.00

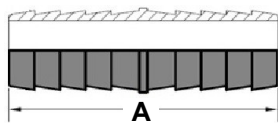

HM-90 90° HOSE MENDER

PART NUMBER	HOSE ID	A	B
HM-90-2	1/8"	.73	.46
HM-90-3	3/16"	1.05	.79
HM-90-4	1/4"	1.05	.79
HM-90-5	5/16"	1.15	.79
HM-90-6	3/8"	1.15	.79
HM-90-8	1/2"	1.25	.87
HM-90-10	5/8"	1.30	.87
HM-90-12	3/4"	1.41	.89

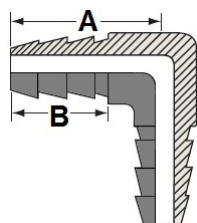

HBT2 HOSE BARB TEE

PART NUMBER	HOSE ID	A	B
HBT2-2	1/8"	.71	.46
HBT2-3	3/16"	.94	.71
HBT2-4	1/4"	.94	.71
HBT2-5	5/16"	1.18	.79
HBT2-6	3/8"	1.26	.86
HBT2-8	1/2"	1.26	.86
HBT2-10	5/8"	1.33	.90
HBT2-12	3/4"	1.41	.90

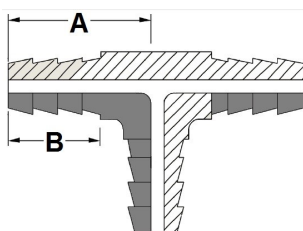

122RWA WELDING ADAPTER 9/16-18 RH

PART NUMBER	MPT	RH THREAD
122RWA-B	1/4"	9/16-18 RH
122RWA-C	3/8"	9/16-18 RH

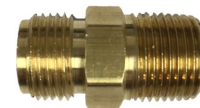

209RWA HOSE TO 9/16-18 RH

PART NUMBER	HOSE I.D.	THREAD	HEX
209RWA-3	3/16"	9/16-18 RH	11/16"
209RWA-4	1/4"	9/16-18 RH	11/16"
209RWA-5	5/16"	9/16-18 RH	11/16"
209RWA-6	3/8"	9/16-18 RH	11/16"



122LWA HOSE TO 9/16-18 LH

PART NUMBER	PIPE	LH THREAD
122LWA-B	1/4"	9/16-18 LH
122LWA-C	3/8"	9/16-18 LH



209LWA HOSE TO 9/16-18 LH

PART NUMBER	HOSE I.D.	LH THREAD	HEX
209RWA-3	3/16"	9/16-18 LH	11/16"
209RWA-4	1/4"	9/16-18 LH	11/16"
209RWA-5	5/16"	9/16-18 LH	11/16"
209RWA-6	3/8"	9/16-18 LH	11/16"



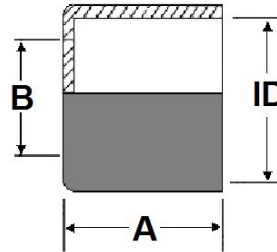

BF CRIMP ON FERRULE

PART NUMBER	Cross Ref.	I.D.	LENGTH (A)	HOLE (B)	THICKNESS
BF-.330-.490-.250	6231	.330	.490	.250	.020
BF-.358-.500-.265	833	.358	.500	.265	.020
BF-.380-.500-.265	622	.380	.500	.265	.020
BF-.400-.470-.270	619	.400	.470	.270	.020
BF-.410-.500-.265	620	.410	.500	.265	.020
BF-.450-.562-.343	769	.450	.562	.343	.020
BF-.478-.687-.328	4750	.478	.687	.328	.025
BF-.500-1.00-.343	7322	.500	1.00	.343	.025
BF-.500-.500-.343	624	.500	.500	.343	.020
BF-.525-1.00-.375	7323	.525	1.00	.375	.025
BF-.525-1.00-.437	9974	.525	1.00	.437	.025
BF-.525-.470-.360	625	.525	.470	.360	.020
BF-.531-1.00-.375	7324	.531	1.00	.375	.025
BF-.560-1.00-.437	7325	.560	1.00	.437	.025
BF-.560-.750-.375	3588	.560	.750	.375	.020
BF-.575-.484-.468	KK	.575	.484	.468	.020
BF-.593-1.00-.437	7326	.593	1.00	.437	.025
BF-.600-.500-.500	JJ	.600	.500	.500	.020
BF-.625-.500-.500	II	.625	.500	.500	.020
BF-.625-1.00-.437	7327	.625	1.00	.437	.025
BF-.650-.500-.500	HH	.650	.500	.500	.020
BF-.656-1.00-.437	7328	.656	1.00	.437	.025
BF-.675-.515-.500	GG	.675	.515	.500	.020
BF-.690-1.00-.500	7329	.690	1.00	.500	.025
BF-.718-1.00-.625	7330A	.718	1.00	.625	.025
BF-.725-.530-.500	EE	.725	.530	.500	.020
BF-.750-.531-.500	DD	.750	.531	.500	.020
BF-.750-1.00-.625	7331	.750	1.00	.625	.025
BF-.775-.531-.500	CC	.775	.531	.500	.020
BF-.781-1.00-.625	7332	.781	1.00	.625	.025
BF-.812-1.00-.625	7333	.812	1.00	.625	.025
BF-.875-.843-.687	7244A	.875	.843	.687	.025
BF-.937-.875-.750	7242	.937	.875	.750	.025
BF-.975-.843-.687	5028A	.975	.843	.687	.025
BF-1.025-.843-.687	7114A	1.025	.843	.687	.025
BF-1.150-.843-.875	7104A	1.150	.843	.875	.025
BF-1.175-.875-.875	7088A	1.175	.875	.875	.025
BF-1.500-.875-1.125	1500	1.500	.875	1.125	.025





BRASS PUSH-LOK HOSE BARBS

CONSTRUCTION	<ul style="list-style-type: none"> • CA360, CA345, CA3604, CA377 Brass 
APPLICATIONS	<ul style="list-style-type: none"> • Use with thermoplastic or rubber push-lock hose. No use of hose clamp or crimped type fitting required. 
RANGES	<ul style="list-style-type: none"> • Temperature Range: -30° to +180° F. 



PUSH-LOK FITTING ASSEMBLY

1. Make a clean square cut on your hose end.
2. Use lubricant on the end of the hose.
3. Move the fitting into the hose so only one barb is inserted into the hose. Make sure the fitting is lined up properly with the hose.
4. Push the fitting fully into the hose so that the end of the hose is covered by the yellow plastic cap. Make sure the fitting is fully inserted before use.

ORDERING INFORMATION

- Parts that include “PBF” are supplied as low lead compliant fittings.
- Part numbers without the “PBF” distinction are NOT lead free compliant.
- Nomenclature Example:

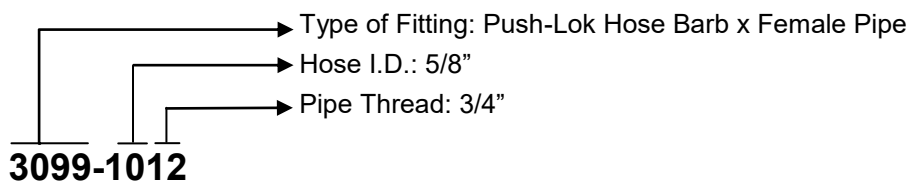









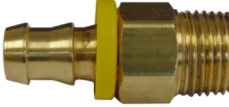



NOTES

- Non-stock items and special parts are available on a quotation basis.
- Configurations and dimensions are subject to change without notice.

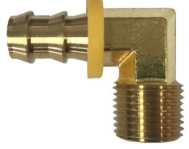

⚠ WARNING: Products offered by Robo-Fit, Inc. can expose you to chemicals such as lead, a chemical which is known to the State of California to cause cancer, birth defects, or other reproductive harm. For more information go to www.P65Warnings.ca.gov

<p>301 Hose Barb to MPT</p> 	<p>301-SV Hose Barb to MPT Swivel</p> 	<p>302 Hose Barb to 45° Male Flare</p> 	<p>303 Rigid Tube Shank</p> 
<p>304 Hose Splicer</p> 	<p>305 Hose Barb to Inverted Flare</p> 	<p>306 Hose Barb to Inverted Flare</p> 	<p>307 Hose to 45° Flare, Swivel</p> 
<p>308 Hose to 37° Flare, Swivel</p> 	<p>309 Hose to Dual Angle, 45°/37°</p> 	<p>3099 Hose Barb to Female Pipe</p> 	<p>3099-SV Hose Barb to FPT Swivel</p> 
<p>310 Hose Barb to Male 37° Flare</p> 	<p>1000B 90° Hose Barb to Male Pipe</p> 		

301 HOSE BARB TO MPT

PART NUMBER	HOSE ID	MPT	A	B	HEX
301-42	3/16"	1/8"-27	.87	1.43	1/2"
301-44	3/16"	1/4"-18	.87	1.66	9/16"
301-46	1/4"	3/8"-18	.87	1.66	11/16"
301-52	5/16"	1/8"-27	.87	1.43	1/2"
301-54	5/16"	1/4"-18	.87	1.66	9/16"
301-62	3/8"	1/8"-27	.97	1.53	1/2"
301-64	3/8"	1/4"-18	.97	1.76	9/16"
301-66	3/8"	3/8"-18	.97	1.76	11/16"
301-68	3/8"	1/2"-14	.97	1.97	7/8"
301-84	1/2"	1/4"-18	.97	1.76	11/16"
301-86	1/2"	3/8"-18	.97	1.76	11/16"
301-88	1/2"	1/2"-14	.97	1.97	7/8"
301-812	1/2"	3/4"-14	.97	1.97	1 1/16"
301-108	5/8"	1/2"-14	1.45	2.45	7/8"
301-1012	5/8"	3/4"-14	1.45	2.45	1 1/16"
301-128	3/4"	1/2"-14	1.45	2.45	7/8"
301-1212	3/4"	3/4"-14	1.45	2.45	1 1/16"

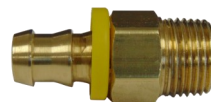
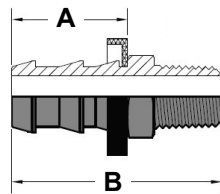

302 HOSE BARB TO 45° MALE FLARE

PART NUMBER	HOSE ID	FLARE THREAD	A	B	HEX
302-44	1/4"	1/4"	1.56	.75	7/16"
302-45	1/4"	5/16"	1.66	.84	1/2"
302-66	3/8"	3/8"	1.75	.94	5/8"
302-88	1/2"	1/2"	1.94	1.00	3/4"

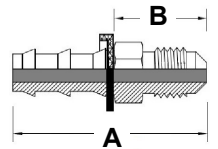

303 RIGID TUBE SHANK

PART NUMBER	HOSE ID	TUBE ID	A	B
303-43	1/4"	3/16"	1.94	1.12
303-44	1/4"	1/4"	2.00	1.19
303-45	1/4"	5/16"	2.03	1.22
303-66	3/8"	3/8"	2.16	1.34
303-88	1/2"	1/2"	2.44	1.48
303-1010	5/8"	5/8"	2.61	1.54

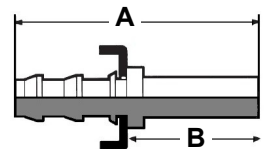

301-SV HOSE BARB TO MPT SWIVEL

PART NUMBER	HOSE ID	MPT	A	B	HEX
301-44-SV	1/4"	1/4"-18	.87	1.71	9/16"
301-5B-SV	5/16"	1/4"-18	.87	1.71	9/16"
301-6B-SV	3/8"	1/4"-18	.97	2.00	9/16"
301-6C-SV	3/8"	3/8"-18	.97	2.00	11/16"
301-8C-SV	1/2"	3/8"-18	.97	2.00	11/16"
301-8D-SV	1/2"	1/2"-14	.97	2.00	7/8"

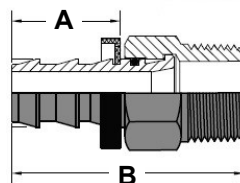

304 HOSE SPLICER

PART NUMBER	HOSE ID	A	B
304-44	1/4"	.87	1.80
304-55	5/16"	.87	1.80
304-66	3/8"	.97	2.00
304-88	1/2"	.97	2.00
304-1010	5/8"	1.45	3.03
304-1212	3/4"	1.45	3.03

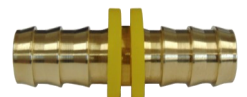
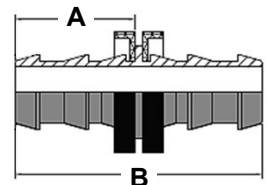

305 HOSE BARB TO INVERTED FLARE

PART NUMBER	HOSE ID	INV FLARE	HEX
305-43	3/16"	3/16"	3/8"
305-44	1/4"	1/4"	7/16"
305-45	1/4"	5/16"	1/2"
305-55	5/16"	5/16"	1/2"
305-66	3/8"	3/8"	5/8"
305-88	1/2"	1/2"	3/4"
305-1010	5/8"	5/8"	7/8"

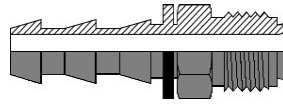

308 HOSE TO FEMALE 37° FLARE, SWIVEL

PART NUMBER	HOSE ID	FLARE THREAD	A	HEX
308-46	1/4"	9/16"-18	.87	1 1/16"
308-56	1/4"	9/16"-18	.87	1 1/16"
308-66	3/8"	3/8"	.97	1 1/16"
308-1212	3/4"	1-1/16"-12	1.45	1 1/4"

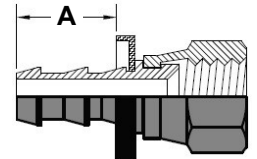

306 HOSE BARB TO INVERTED FEMALE FLARE

PART NUMBER	HOSE ID	INV FLARE	HEX
306-43	1/4"	3/16"	7/16"
306-44	1/4"	1/4"	1/2"
306-45	1/4"	5/16"	9/16"
306-66	3/8"	3/8"	3/4"
306-88	1/2"	1/2"	7/8"

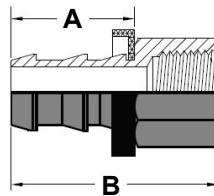

309 HOSE TO DUAL ANGLE, SWIVEL, 45°/37°

PART NUMBER	HOSE ID	FLARE THREAD	A	HEX
309-44	1/4"	7/16"-20	.87	9/16"
309-45	1/4"	1/2"-20	.87	5/8"
309-55	5/16"	1/2"-20	.87	5/8"
309-68	3/8"	3/4"-16	.97	7/8"
309-88	1/2"	3/4"-16	.97	7/8"
309-810	1/2"	7/8"-14	.97	1"
309-108	5/8"	3/4"-16	1.45	7/8"
309-1010	5/8"	7/8"-14	1.45	1"
309-1210	3/4"	7/8"-14	1.45	1"

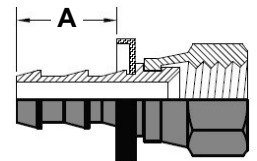

307 HOSE TO FEMALE 45° FLARE, SWIVEL

PART NUMBER	HOSE ID	FLARE THREAD	HEX	A
307-46	1/4"	5/8"-18	3/4"	.87
307-56	5/16"	5/8"-18	3/4"	.87
307-66	3/8"	5/8"-18	3/4"	.97
307-1212	3/4"	1 1/16"-14	1 1/4"	1.45

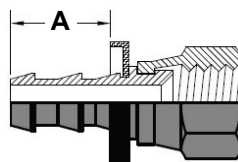

3099 HOSE TO FEMALE PIPE

PART NUMBER	HOSE ID	FPT	A	B	HEX
3099-42	1/4"	1/8"-27	.87	1.35	1/2"
3099-44	1/4"	1/4"-18	.87	1.51	5/8"
3099-46	1/4"	3/8"-18	.87	1.53	3/4"
3099-52	5/16"	1/8"-27	.87	1.35	1/2"
3099-54	5/16"	1/4"-18	.87	1.51	5/8"
3099-62	3/8"	1/8"-27	.97	1.45	1/2"
3099-64	3/8"	1/4"-18	.97	1.61	5/8"
3099-66	3/8"	3/8"-18	.97	1.63	3/4"
3099-68	3/8"	1/2"-14	.97	1.77	15/16"
3099-84	1/2"	1/4"-18	.97	1.61	5/8"
3099-86	1/2"	3/8"-18	.97	1.63	3/4"
3099-88	1/2"	1/2"-14	.97	1.77	15/16"
3099-812	1/2"	3/4"-14	.97	1.77	1 1/8"
3099-108	5/8"	1/2"-14	1.45	2.25	15/16"
3099-1012	5/8"	3/4"-14	1.45	2.25	1 1/8"
3099-128	3/4"	1/2"-14	1.45	2.25	15/16"
3099-1212	3/4"	3/4"-14	1.45	2.25	1 1/8"

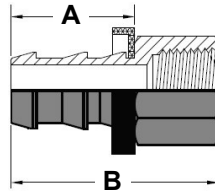

310 HOSE TO JIC MALE 37°

PART NUMBER	HOSE ID	37° Male Flare	A	HEX
310-44	1/4"	7/16"-20	1.57	1/2"
310-45	1/4"	1/2"-20	1.60	9/16"
310-66	3/8"	9/16"-18	1.60	9/16"
310-88	1/2"	3/4"-16	1.97	3/4"

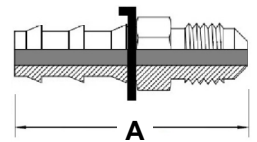

3099-SV HOSE BARB TO FPT, SWIVEL

PART NUMBER	HOSE ID	FPT	A	HEX
3099-44-SV	1/4"	1/4"-18	.87	5/8"
3099-54-SV	5/16"	1/4"-18	.87	5/8"
3099-64-SV	3/8"	1/4"-18	.97	5/8"
3099-86-SC	1/2"	3/8"-18	.97	3/4"
3099-88-SV	1/2"	1/2"-14	.97	15/16"

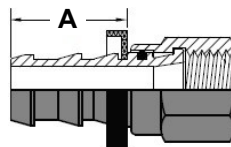

1000B 90° HOSE BARB TO MPT

PART NUMBER	HOSE ID	MPT	A	B
10004B-C02	1/4"	1/8"-27	1.22	.82
10004B-C04	1/4"	1/4"-18	1.40	.82
10005B-C02	5/16"	1/8"-27	1.08	.87
10005B-C04	5/16"	1/4"-18	1.15	.87
10006B-C02	3/8"	1/8"-27	1.35	.92
10006B-C04	3/8"	1/4"-18	1.40	.92
10006B-C06	3/8"	3/8"-18	1.51	.92
10008B-C06	1/2"	3/8"-18	1.54	1.02
10008B-C08	1/2"	1/2"-14	1.61	1.02
10012B-C08	3/4"	1/2"-14	2.15	1.50
10012B-C12	3/4"	3/4"-14	2.23	1.50

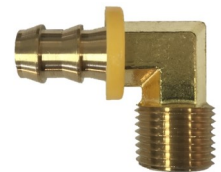
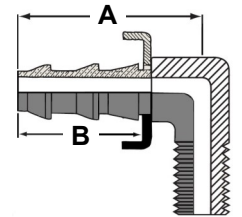



NYLON AIR BRAKE DOT FITTINGS

CONSTRUCTION

- CA360 Brass (Straights)
- CA360 Brass (Shapes)

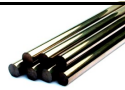

APPLICATIONS

- Air Brake Systems



- Temperature Range: -40° to 200° F.

RANGES

- Pressure Range: Up to 150 PSI



Assembly Instructions

1. Cut tubing squarely—using a tube cutter.
2. Make sure all fittings involved in the assembly are clean of burrs and debris.
3. Insert nylon air brake tubing firmly into the fitting until it bottoms out.
4. Tighten nut according to the chart listed below:

Tube Size	Turns Past Hand-Tight
3/16	2.5
1/4	3
3/8 + 1/2	4
5/8 + 3/4	3.5

Application Details:

Transportation Air Brake Systems, Air Suspensions, Cabin Controls:

Trucks, Trailers, RVs, Buses, Fire Trucks, & Rail.



NOTES

- Fittings meet SAE and DOT FMVSS 571.106
- Non-stock items and special parts are available on a quotation basis.
- Configurations and dimensions are subject to change without notice.

⚠ WARNING: Products offered by Robo-Fit, Inc. can expose you to chemicals such as lead, a chemical which is known to the State of California to cause cancer, birth defects, or other reproductive harm. For more information go to www.P65Warnings.ca.gov

<p>59A Tube Support Insert</p> 	<p>60NAB Sleeve</p> 	<p>61NAB Nut</p> 	<p>62NAB Union Tube, Both Ends</p> 
<p>62NABH Bulkhead Union</p> 	<p>64NAB Union Tee</p> 	<p>65NAB 90° Union Elbow</p> 	<p>66NAB Female Connector</p> 
<p>68NAB Male Connector</p> 	<p>68NABH Bulkhead Connector</p> 	<p>69NAB 90° Male Elbow</p> 	<p>70NAB 90° Female Elbow</p> 
<p>71NAB Male Run Tee</p> 	<p>72NAB Male Branch Tee</p> 	<p>79NAB 45° Male Elbow</p> 	

59A TUBE SUPPORT INSERT

PART NUMBER	Tube O.D.	A
59A-4	1/4"	.51
59A-6	3/8"	.64
59A-8	1/2"	.81
59A-10	5/8"	.86
59A-12	3/4"	1.06

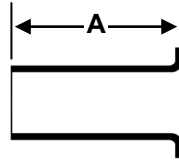

62NAB UNION TUBE, BOTH ENDS

PART NUMBER	Tube O.D.	A	HEX
62NAB-4	1/4"	1.45	7/16"
62NAB-6	3/8"	1.80	9/16"
62NAB-8	1/2"	2.03	11/16"
62NAB-10	5/8"	2.29	13/16"
62NAB-12	3/4"	2.62	1"

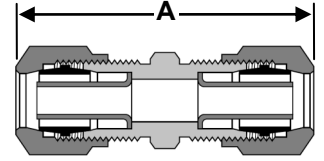

REF SAE 100101BA

60NAB SLEEVE

PART NUMBER	Tube O.D.	A
60NAB-4	1/4"	.31
60NAB-6	3/8"	.39
60NAB-8	1/2"	.43
60NAB-10	5/8"	.44
60NAB-12	3/4"	.54



REF SAE 100115BA

62NABH BULKHEAD UNION, BOTH ENDS

PART NUMBER	Tube O.D.	A	Hex
62NABH-6	3/8"	2.90	9/16"
62NABH-8	1/2"	3.20	11/16"

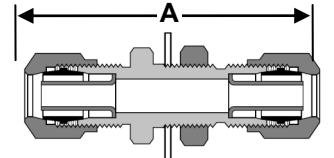

61NAB NUT

PART NUMBER	Tube O.D.	A	HEX
61NAB-4	1/4"	.45	9/16"
61NAB-6	3/8"	.56	5/8"
61NAB-8	1/2"	.66	13/16"
61NAB-10	5/8"	.74	15/16"
61NAB-12	3/4"	.81	1-1/8"

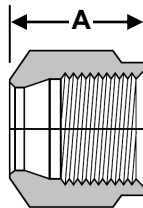

REF SAE 100110BA

64NAB UNION TEE

PART NUMBER	Tube O.D.	A
64NAB-4	1/4"	.95
64NAB-6	3/8"	1.24
64NAB-8	1/2"	1.45
64NAB-10	5/8"	1.58

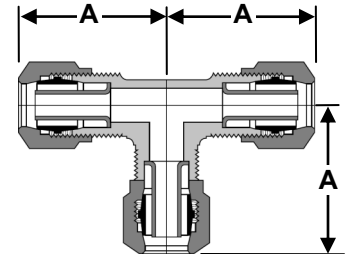

REF SAE 100401BA

65NAB 90° UNION ELBOW

PART NUMBER	Tube O.D.	A
65NAB-4	1/4"	1.00
65NAB-6	3/8"	1.14
65NAB-8	1/2"	1.32
65NAB-10	5/8"	1.60

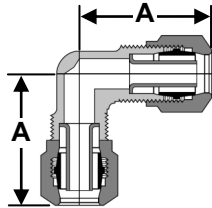

REF SAE 100201BA

66NAB FEMALE CONNECTOR

PART NUMBER	Tube O.D.	FPT	A	HEX
66NAB-4A	1/4"	1/8"	1.18	9/16"
66NAB-4B	1/4"	1/4"	1.40	11/16"
66NAB-6A	3/8"	1/8"	1.50	9/16"
66NAB-6B	3/8"	1/4"	1.60	11/16"
66NAB-6C	3/8"	3/8"	1.71	7/8"
66NAB-8C	1/2"	3/8"	1.80	7/8"
66NAB-8D	1/2"	1/2"	1.89	1-1/16"

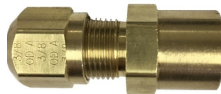
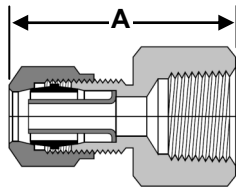

REF SAE 100103BA

68NAB MALE CONNECTOR

PART NUMBER	Tube O.D.	MPT	A	HEX
68NAB-4A	1/4"	1/8"	1.21	7/16"
68NAB-4B	1/4"	1/4"	1.42	9/16"
68NAB-4C	1/4"	3/8"	1.46	11/16"
68NAB-6A	3/8"	1/8"	1.37	9/16"
68NAB-6B	3/8"	1/4"	1.58	9/16"
68NAB-6C	3/8"	3/8"	1.58	11/16"
68NAB-6D	3/8"	1/2"	1.80	7/8"
68NAB-8B	1/2"	1/4"	1.71	11/16"
68NAB-8C	1/2"	3/8"	1.71	11/16"
68NAB-8D	1/2"	1/2"	1.90	7/8"
68NAB-10C	5/8"	3/8"	1.84	13/16"
68NAB-10D	5/8"	1/2"	2.03	7/8"
68NAB-12D	3/4"	1/2"	2.21	1"
68NAB-12E	3/4"	3/4"	2.22	1-1/16"

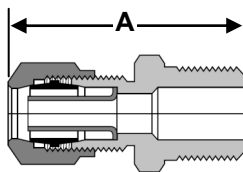

REF SAE 100102BA

69NAB 90° MALE ELBOW

PART NUMBER	Tube O.D.	MPT	A	B
69NAB-4A	1/4"	1/8"	.95	.66
69NAB-4B	1/4"	1/4"	1.00	.87
69NAB-4C	1/4"	3/8"	1.16	.86
69NAB-6A	3/8"	1/8"	1.19	.75
69NAB-6B	3/8"	1/4"	1.25	.92
69NAB-6C	3/8"	3/8"	1.30	.91
69NAB-6D	3/8"	1/2"	1.40	1.10
69NAB-8B	1/2"	1/4"	1.38	.99
69NAB-8C	1/2"	3/8"	1.44	.99
69NAB-8D	1/2"	1/2"	1.55	1.18
69NAB-10C	5/8"	3/8"	1.49	1.05
69NAB-10D	5/8"	1/2"	1.58	1.24
69NAB-10E	5/8"	3/4"	1.76	1.32
69NAB-12D	3/4"	1/2"	1.70	1.33
69NAB-12E	3/4"	3/4"	1.77	1.32

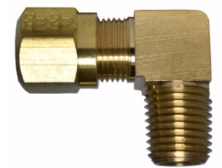
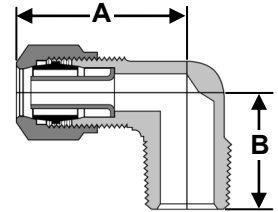

REF SAE 100202BA

68NABH BULKHEAD CONNECTOR

PART NUMBER	Tube O.D.	FPT	A	HEX
68NABH-6C	3/8"	3/8"	1.31	1-1/16"
68NABH-8C	1/2"	3/8"	1.93	1-1/16"

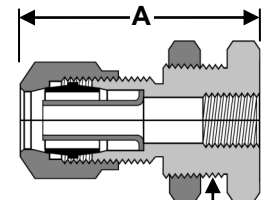

7/8" -20 UNEF-2A



70NAB 90° FEMALE ELBOW

PART NUMBER	Tube O.D.	FPT	A	B
70NAB-4A	1/4"	1/8"	1.02	.52
70NAB-4B	1/4"	1/4"	1.11	.71
70NAB-6A	3/8"	1/8"	1.29	.59
70NAB-6B	3/8"	1/4"	1.35	.77
70NAB-6C	3/8"	3/8"	1.39	.77
70NAB-8C	1/2"	3/8"	1.55	.82
70NAB-8D	1/2"	1/2"	1.65	1.01
70NAB-10D	5/8"	1/2"	1.70	1.07

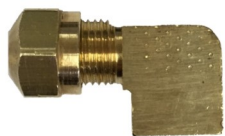
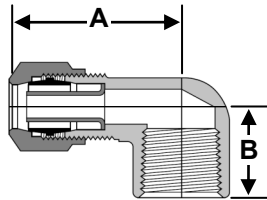

REF SAE 100203BA

72NAB MALE BRANCH TEE

PART NUMBER	Tube O.D.	MPT	A	B
72NAB-4A	1/4"	1/8"	.66	1.80
72NAB-4B	1/4"	1/4"	.87	2.00
72NAB-6A	3/8"	1/8"	.75	2.36
72NAB-6B	3/8"	1/4"	.92	2.50
72NAB-6C	3/8"	3/8"	.91	2.60
72NAB-8B	1/2"	1/4"	.99	2.82
72NAB-8C	1/2"	3/8"	.99	2.90
72NAB-8D	1/2"	1/2"	1.18	3.10
72NAB-10D	5/8"	1/2"	1.24	3.20

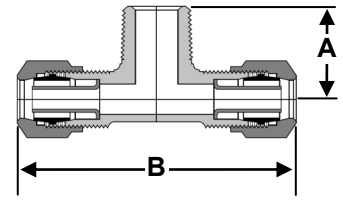

REF SAE 100425BA

71NAB MALE RUN TEE

PART NUMBER	Tube O.D.	MPT	A	B
71NAB-4A	1/4"	1/8"	.95	1.61
71NAB-4B	1/4"	1/4"	1.00	1.87
71NAB-6B	3/8"	1/4"	1.25	2.17
71NAB-6C	3/8"	3/8"	1.30	2.21
71NAB-8C	1/2"	3/8"	1.45	2.44
71NAB-8D	1/2"	1/2"	1.55	2.73
71NAB-10D	5/8"	1/2"	1.60	2.84

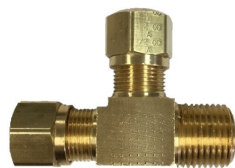
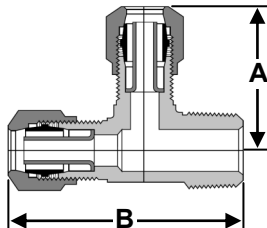

REF SAE 100424BA

79NAB 45° MALE ELBOW

PART NUMBER	Tube O.D.	MPT	A	B
79NAB-4A	1/4"	1/8"	.81	.63
79NAB-4B	1/4"	1/4"	.93	.85
79NAB-6A	3/8"	1/8"	1.17	.68
79NAB-6B	3/8"	1/4"	1.17	.85
79NAB-6C	3/8"	3/8"	1.21	.94
79NAB-6D	3/8"	1/2"	1.24	1.16
79NAB-8B	1/2"	1/4"	1.36	.94
79NAB-8C	1/2"	3/8"	1.36	.94
79NAB-8D	1/2"	1/2"	1.39	1.16
79NAB-10C	5/8"	3/8"	1.43	.98
79NAB-10D	5/8"	1/2"	1.42	1.16
79NAB-12D	3/4"	1/2"	1.61	1.18

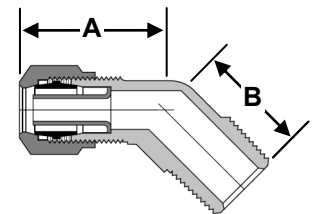



BRASS PUSH-IN DOT FITTINGS

CONSTRUCTION	<ul style="list-style-type: none"> • CA360/CA3604 Brass (Straights) • CA377/CA3604 Brass (Shapes) • "O" Ring: Buna N (Nitrile) 	
APPLICATIONS	<ul style="list-style-type: none"> • Air Brake Systems 	
RANGES	<ul style="list-style-type: none"> • Temperature Range: -40° to 200° F. • Pressure Range: Up to 200 PSI 	



To Connect Fitting & Tubing:

1. Cut the air brake tubing squarely.
2. Make sure mating ports are free of any debris.
3. Insert the tubing past the O-Ring until the tubing bottoms out against the tube stop.
4. Check your connection by pulling on the tubing to ensure tubing is fully inserted.

To Disconnect Fitting & Tubing:

1. Press and hold the collet against the fitting body.
2. Pull the tubing out of fitting.

Application Details:

Transportation Air Brake Systems, Air Suspensions, Cabin Controls:

Trucks, Trailers, RVs, Buses, Fire Trucks, & Rail.



NOTES

- Fittings meet SAE and DOT FMVSS 571.106
- Non-stock items and special parts are available on a quotation basis.
- Configurations and dimensions are subject to change without notice.

⚠ WARNING: Products offered by Robo-Fit, Inc. can expose you to chemicals such as lead, a chemical which is known to the State of California to cause cancer, birth defects, or other reproductive harm. For more information go to www.P65Warnings.ca.gov

<p>259PPDOT Tube Plug</p> 	<p>262PPDOT Union</p> 	<p>262PPBHDOT Bulkhead Union</p> 	<p>264PPDOT Union Tee</p> 
<p>265PPDOT 90° Union Elbow</p> 	<p>266PPDOT Female Connector</p> 	<p>268PPDOT Male Connector</p> 	<p>2688PPDOT Plug In Adapter</p> 
<p>269PPDOT 90° Male Elbow</p> 	<p>269PPSDOT 90° Male Swivel Elbow</p> 	<p>270PPDOT 90° Female Elbow</p> 	<p>270PPSDOT 90° Female Swivel Elbow</p> 
<p>271PPDOT Male Run Tee</p> 	<p>271PPSDOT Male Swivel Run Tee</p> 	<p>272PPDOT Male Branch Tee</p> 	<p>272PPSDOT Male Swivel Branch Tee</p> 
<p>277PPDOT Female Branch Tee</p> 	<p>277PPSDOT Female Swivel Branch Tee</p> 	<p>279PPDOT 45° Male Elbow</p> 	<p>279PPSDOT 45° Male Swivel Elbow</p> 
<p>283PPDOT Gladhand Bulkhead</p> 	<p>286PPDOT Female Bulkhead</p> 		

259PPDOT NYLON PLUG

PART NUMBER	A
259PPDOT-2.5	5/32"
259PPDOT-4	1/4"
259PPDOT-6	3/8"
259PPDOT-8	1/2"
259PPDOT-10	5/8"
259PPDOT-12	3/4"



262PPDOT UNION CONNECTOR

PART NUMBER	Tube O.D.	A	B
262PPDOT-2.5	5/32"	1.38	3/8"
262PPDOT-3	3/16"	1.60	7/16"
262PPDOT-4	1/4"	1.82	7/16"
262PPDOT-2.5	5/16"	1.89	19/32"
262PPDOT-6	3/8"	1.82	21/32"
262PPDOT-8	1/2"	2.02	25/32"
262PPDOT-10	5/8"	2.04	.91
262PPDOT-12	3/4"	2.20	1.06

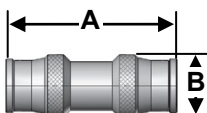

262PPBHDOT BULKHEAD UNION

PART NUMBER	Tube O.D.	A	C	D
262PPBHDOT-4	1/4"	1.90	3/8	1/2-20
262PPBHDOT-6	3/8"	1.85	7/16	3/4-16
262PPBHDOT-8	1/2"	2.05	7/16	15/16-16
262PPBHDOT-10	5/8"	2.05	19/32	1/4

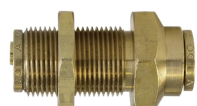
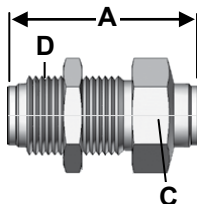

264PPDOT UNION TEE

PART NUMBER	Tube O.D.	A	B	FLATS
264PPDOT-4	1/4"	.94	1.17	3/8"
264PPDOT-6	3/8"	1.08	1.41	1/2"
264PPDOT-8	1/2"	1.26	1.65	5/8"
264PPDOT-10	5/8"	1.32	1.77	11/16"
264PPDOT-12	3/4"	1.44	1.99	15/16"

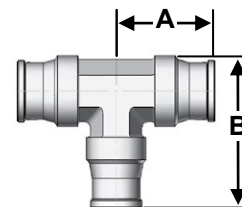

265PPDOT 90° UNION ELBOW

PART NUMBER	Tube O.D.	A	B	FLATS
265PPDOT-4	1/4"	.94	1.17	3/8"
265PPDOT-6	3/8"	1.08	1.41	1/2"
265PPDOT-8	1/2"	1.26	1.65	5/8"

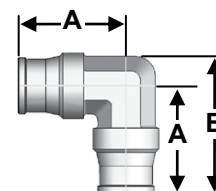

266PPDOT FEMALE CONNECTOR

PART NUMBER	Tube O.D.	FPT	A	HEX
266PPDOT-4A	1/4"	1/8"	1.33	9/16"
266PPDOT-4B	1/4"	1/4"	1.55	3/4"
266PPDOT-6A	3/8"	1/8"	1.33	11/16"
266PPDOT-6B	3/8"	1/4"	1.52	3/4"
266PPDOT-6C	3/8"	3/8"	1.56	7/8"
266PPDOT-8C	1/2"	3/8"	1.59	7/8"
266PPDOT-8D	1/2"	1/2"	1.85	1-1/8"

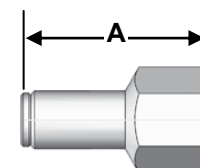

268PPDOT MALE CONNECTOR

PART NUMBER	Tube O.D.	MPT	A	HEX
268PPDOT-2.5X1	5/32"	1/16"	.78	3/8"
268PPDOT-2.5A	5/32"	1/8"	.79	7/16"
268PPDOT-2.5B	5/32"	1/4"	.95	9/16"
268PPDOT-3X0	3/16"	10/32"	.89	3/8"
268PPDOT-3X1	3/16"	1/16"	1.02	3/8"
268PPDOT-3A	3/16"	1/8"	1.02	7/16"
268PPDOT-3B	3/16"	1/4"	1.02	9/16"
268PPDOT-4X1	1/4"	1/16"	1.17	7/16"
268PPDOT-4A	1/4"	1/8"	.98	7/16"
268PPDOT-4B	1/4"	1/4"	.90	9/16"
268PPDOT-4C	1/4"	3/8"	.87	11/16"
268PPDOT-6A	3/8"	1/8"	1.17	11/16"
268PPDOT-6B	3/8"	1/4"	1.15	11/16"
268PPDOT-6C	3/8"	3/8"	1.12	11/16"
268PPDOT-6D	3/8"	1/2"	1.03	7/8"
268PPDOT-8B	1/2"	1/4"	1.46	13/16"
268PPDOT-8C	1/2"	3/8"	1.28	13/16"
268PPDOT-8D	1/2"	1/2"	1.23	7/8"
268PPDOT-8E	1/2"	3/4"	1.29	1-1/16"
268PPDOT-10C	5/8"	3/8"	1.44	15/16"
268PPDOT-10D	5/8"	1/2"	1.59	15/16"
268PPDOT-10E	5/8"	3/4"	1.13	1-1/16"
268PPDOT-12D	3/4"	1/2"	1.65	1-1/16"
268PPDOT-12E	3/4"	3/4"	1.38	1-1/16"

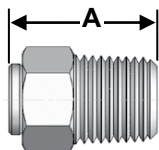

269PPDOT 90° MALE ELBOW

PART NUMBER	Tube O.D.	MPT	A	B	C
269PPDOT-2.5X1	5/32"	1/16"	.78	.65	5/16"
269PPDOT-2.5A	5/32"	1/8"	.78	.69	5/16"
269PPDOT-3A	3/16"	1/8"	.88	.75	3/8"
269PPDOT-4A	1/4"	1/8"	1.01	.79	3/8"
269PPDOT-4B	1/4"	1/4"	1.05	.84	3/8"
269PPDOT-4C	1/4"	3/8"	1.10	.98	1/2"
269PPDOT-6A	3/8"	1/8"	1.00	.80	1/2"
269PPDOT-6B	3/8"	1/4"	1.10	.98	1/2"
269PPDOT-6C	3/8"	3/8"	1.08	.98	1/2"
269PPDOT-6D	3/8"	1/2"	1.14	1.20	5/8"
269PPDOT-8B	1/2"	1/4"	1.26	1.05	5/8"
269PPDOT-8C	1/2"	3/8"	1.26	1.05	5/8"
269PPDOT-8D	1/2"	1/2"	1.25	1.26	5/8"
269PPDOT-10C	5/8"	3/8"	1.25	1.26	5/8"
269PPDOT-10D	5/8"	1/2"	1.34	1.29	11/16"
269PPDOT-12D	3/4"	1/2"	1.32	1.36	15/16"
269PPDOT-12E	3/4"	3/4"	1.32	1.36	15/16"

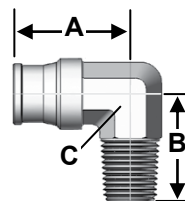

2688PPDOT PRESS-IN CARTRIDGE

PART NUMBER	Tube O.D.	A	B	C
2688PPDOT-2.5	5/32"	.59	.69	.32
2688PPDOT-3	3/16"	.68	.78	.41
2688PPDOT-4	1/4"	.76	.86	.41
2688PPDOT-6	3/8"	.82	.92	.64
2688PPDOT-8	1/2"	.92	1.02	.77

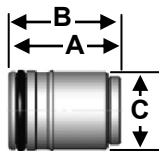

269PPSDOT 90° MALE SWIVEL ELBOW

PART NUMBER	Tube O.D.	MPT	A	B	HEX
269PPSDOT-2.5A	5/32"	1/8"	.79	.88	7/16"
269PPSDOT-2.5B	5/32"	1/4"	.79	1.08	9/16"
269PPSDOT-3A	3/16"	1/8"	.88	.92	7/16"
269PPSDOT-4A	1/4"	1/8"	.94	1.09	9/16"
269PPSDOT-4B	1/4"	1/4"	.99	1.09	9/16"
269PPSDOT-4C	1/4"	3/8"	1.02	1.13	11/16"
269PPSDOT-6A	3/8"	1/8"	1.05	1.06	7/16"
269PPSDOT-6B	3/8"	1/4"	1.08	1.14	9/16"
269PPSDOT-6C	3/8"	3/8"	1.10	1.23	11/16"
269PPSDOT-6D	3/8"	1/2"	1.10	1.53	7/8"
269PPSDOT-8B	1/2"	1/4"	1.26	1.26	9/16"
269PPSDOT-8C	1/2"	3/8"	1.26	1.31	11/16"
269PPSDOT-8D	1/2"	1/2"	1.25	1.61	7/8"
269PPSDOT-10C	5/8"	3/8"	1.54	1.41	11/16"
269PPSDOT-10D	5/8"	1/2"	1.54	1.71	7/8"
269PPSDOT-12D	3/4"	1/2"	1.40	2.04	1-1/16"
269PPSDOT-12E	3/4"	3/4"	1.40	1.60	1-1/16"

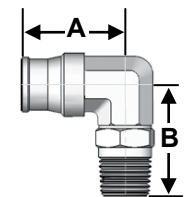

270PPDOT 90° FEMALE ELBOW

PART NUMBER	Tube O.D.	FPT	A	B	C
270PPDOT-4A	1/4"	1/8"	1.02	.83	1.06
270PPDOT-4B	1/4"	1/4"	1.13	1.03	1.31
270PPDOT-4C	1/4"	3/8"	1.27	.99	1.35
270PPDOT-6B	3/8"	1/4"	1.08	.98	1.31
270PPDOT-6C	3/8"	3/8"	1.08	1.05	1.41
269PPDOT-8D	1/2"	1/2"	1.37	1.31	1.70

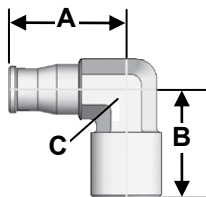

271PPSDOT MALE SWIVEL RUN TEE

PART NUMBER	Tube O.D.	MPT	A	B	C
271PPSDOT-4A	1/4"	1/8"	2.03	1.02	3/8"
271PPSDOT-4B	1/4"	1/4"	2.10	1.02	7/16"
271PPSDOT-6B	3/8"	1/4"	2.19	1.04	1/2"
271PPSDOT-6C	3/8"	3/8"	2.23	1.06	1/2"
271PPSDOT-8C	1/2"	3/8"	2.52	1.24	5/8"
271PPSDOT-8D	1/2"	1/2"	2.82	1.24	5/8"

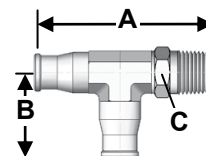

270PPSDOT 90° FEMALE SWIVEL ELBOW

PART NUMBER	Tube O.D.	FPT	A	B	C
270PPSDOT-4A	1/4"	1/8"	.94	1.09	9/16"
270PPSDOT-4B	1/4"	1/4"	.97	1.25	3/4"
270PPSDOT-6B	3/8"	1/4"	1.10	1.48	3/4"

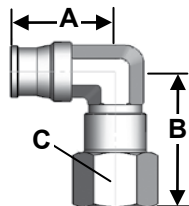

272PPDOT MALE BRANCH TEE

PART NUMBER	Tube O.D.	MPT	A	B
272PPDOT-4A	1/4"	1/8"	1.02	.75
272PPDOT-4B	1/4"	1/4"	1.02	.92
272PPDOT-6A	3/8"	1/8"	1.08	.79
272PPDOT-6B	3/8"	1/4"	1.08	.99
272PPDOT-6C	3/8"	3/8"	1.09	.99
272PPDOT-8B	1/2"	1/4"	1.26	1.07
272PPDOT-8C	1/2"	3/8"	1.26	1.07

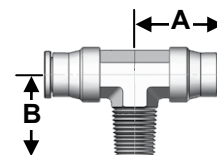

271PPDOT MALE RUN TEE

PART NUMBER	Tube O.D.	MPT	A	B	C
271PPDOT-4A	1/4"	1/8"	1.02	.75	1.02
271PPDOT-4B	1/4"	1/4"	1.02	.92	1.02
271PPDOT-4C	1/4"	3/8"	1.08	.98	1.08
271PPDOT-6B	3/8"	1/4"	1.08	.98	1.08
271PPDOT-6C	3/8"	3/8"	1.08	.98	1.08
271PPDOT-8C	1/2"	3/8"	1.26	1.05	1.26

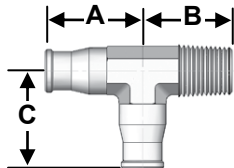

272PPSDOT MALE SWIVEL BRANCH TEE

PART NUMBER	Tube O.D.	MPT	A	B	C
272PPSDOT-4A	1/4"	1/8"	1.02	1.04	7/16"
272PPSDOT-4B	1/4"	1/4"	1.01	1.04	9/16"
272PPSDOT-6A	3/8"	1/8"	1.08	1.07	7/16"
272PPSDOT-6B	3/8"	1/4"	1.06	1.17	9/16"
272PPSDOT-6C	3/8"	3/8"	1.08	1.21	11/16"
272PPSDOT-6D	3/8"	1/2"	1.08	1.40	7/8"
272PPSDOT-8B	1/2"	1/4"	1.26	1.28	9/16"
272PPSDOT-8C	1/2"	3/8"	1.26	1.31	11/16"
272PPSDOT-8D	1/2"	1/2"	1.26	1.61	7/8"
272PPSDOT-10D	5/8"	1/2"	1.32	1.74	7/8"

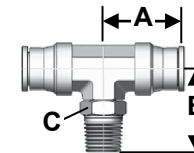

277PPDOT FEMALE BRANCH TEE

PART NUMBER	Tube O.D.	FPT	A	B	C
277PPDOT-4A	1/4"	1/8"	1.02	.82	1/2"
277PPDOT-4B	1/4"	1/4"	1.08	.97	1/2"
277PPDOT-6B	3/8"	1/4"	1.09	.98	1/2"
277PPDOT-6C	3/8"	3/8"	1.40	1.30	11/16"
277PPDOT-8B	1/2"	1/4"	1.26	1.16	5/8"

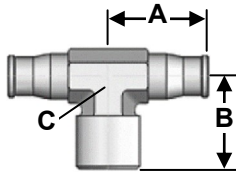

277PPSDOT FEMALE SWIVEL BRANCH TEE

PART NUMBER	Tube O.D.	FPT	A	B	C
277PPSDOT-4A	1/4"	1/8"	1.02	1.13	9/16"
277PPSDOT-4B	1/4"	1/4"	1.02	1.29	3/4"
277PPSDOT-6A	3/8"	1/8"	1.08	1.18	9/16"
277PPSDOT-6C	3/8"	3/8"	1.08	1.16	3/4"

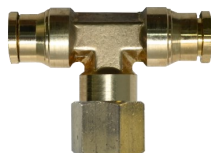
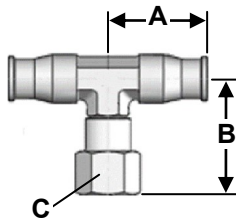

279PPDOT 45° MALE ELBOW

PART NUMBER	Tube O.D.	MPT	A	B
279PPDOT-4A	1/4"	1/8"	.75	.99
279PPDOT-4B	1/4"	1/4"	.89	.99
279PPDOT-6A	3/8"	1/8"	.75	.99
279PPDOT-6B	3/8"	1/4"	.95	1.08
279PPDOT-6C	3/8"	3/8"	.97	1.08
279PPDOT-6D	3/8"	1/2"	1.13	1.15
279PPDOT-8B	1/2"	1/4"	1.00	1.20
279PPDOT-8C	1/2"	3/8"	1.05	1.20
279PPDOT-8D	1/2"	1/2"	1.20	1.20
279PPDOT-10C	5/8"	3/8"	1.17	1.22
279PPDOT-10D	5/8"	1/2"	1.31	1.22
279PPDOT-12D	3/4"	1/2"	1.36	1.18
279PPDOT-12E	3/4"	3/4"	1.36	1.18

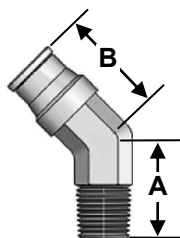

279PPSDOT 45° MALE SWIVEL ELBOW

PART NUMBER	Tube O.D.	MPT	A	B	C
279PPSDOT-4A	1/4"	1/8"	.98	.99	7/16"
279PPSDOT-4B	1/4"	1/4"	1.06	.99	7/16"
279PPSDOT-6A	3/8"	1/8"	1.08	1.06	7/16"
279PPSDOT-6B	3/8"	1/4"	1.13	1.06	9/16"
279PPSDOT-6C	3/8"	3/8"	1.23	1.08	11/16"
279PPSDOT-6D	3/8"	1/2"	1.46	1.22	7/8"
279PPSDOT-8B	1/2"	1/4"	1.22	1.22	9/16"
279PPSDOT-8C	1/2"	3/8"	1.32	1.20	11/16"
279PPSDOT-8D	1/2"	1/2"	1.61	1.20	7/8"
279PPSDOT-10C	5/8"	3/8"	1.38	1.33	11/16"
279PPSDOT-10D	5/8"	1/2"	1.68	1.39	7/8"
279PPSDOT-12E	3/4"	3/4"	2.28	1.40	1-1/16"

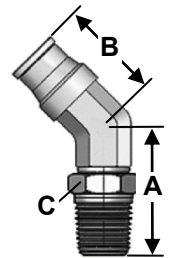

283PPDOT GLADHAND BULKHEAD

PART NUMBER	Tube O.D.	MPT	A	B	C	D
283PPDOT-6D	3/8"	1/2"	1.99	1-3/8	1-1/4	1-14
283PPDOT-8D	1/2"	1/2"	1.99	1-3/8	1-1/4	1-14
283PPDOT-10D	5/8"	1/2"	2.33	1-3/8	1-1/4	1-14

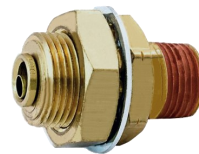
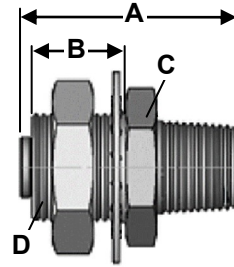

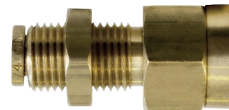
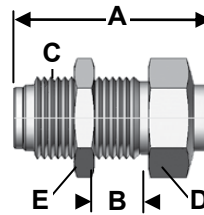

286PPDOT FEMALE BULKHEAD UNION

PART NUMBER	Tube O.D.	FPT	A	B	C	D	E
286PPDOT-4A	1/4"	1/8"	1.32	.64	1/2-20	11/16	11/16
286PPDOT-4B	1/4"	1/4"	1.56	.64	1/2-20	11/16	11/16
286PPDOT-6B	3/8"	1/4"	1.87	1.00	3/4-16	15/16	15/16
286PPDOT-6C	3/8"	3/8"	1.87	1.00	3/4-16	15/16	15/16
286PPDOT-8C	1/2"	3/8"	2.04	1.00	15/16-16	1-1/8	1 3/8

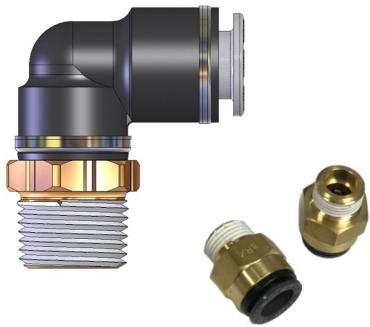

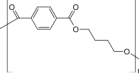

COMPOSITE DOT FITTINGS

CONSTRUCTION	Polybutylene Terephthalate (PBT) Thermoplastic Engineered Polymer
	•Brass 
APPLICATIONS	• Air Brake Systems 
	•Temperature Range: -40° to 140° F
RANGES	• Pressure Range: Up to 145 PSI 

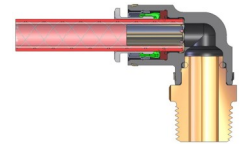

To Connect Fitting & Tubing:

1. Cut the air brake tubing squarely.
2. Make sure mating ports are free of any debris.
3. Insert the tubing past the O-Ring until the tubing bottoms out against the tube stop.
4. Check your connection by pulling on the tubing to ensure tubing is fully inserted.

To Disconnect Fitting & Tubing:

1. Press and hold the collet against the fitting body.
2. Pull the tubing out of fitting.

Application Details:

Transportation Air Brake Systems, Air Suspensions, Cabin Controls:









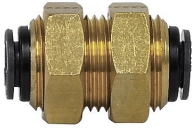

Trucks, Trailers, RVs, Buses, Fire Trucks, & Rail.



NOTES

- Fittings meet SAE and DOT FMVSS 571.106
- Non-stock items and special parts are available on a quotation basis.
- Configurations and dimensions are subject to change without notice.

⚠ WARNING: Products offered by Robo-Fit, Inc. can expose you to chemicals such as lead, a chemical which is known to the State of California to cause cancer, birth defects, or other reproductive harm. For more information go to www.P65Warnings.ca.gov

<p>C259PPDOT Tube Plug</p> 	<p>C262PPDOT Union</p> 	<p>C262PPBHDOT Bulkhead Union</p> 	<p>C264PPDOT Union Tee</p> 
<p>C265PPDOT 90° Union</p> 	<p>C266PPDOT Female Connector</p> 	<p>C268PPDOT Male Connector</p> 	<p>C2688PPDOT Plug In Adapter</p> 
<p>269PPSDOT 90° Male Swivel Elbow</p> 	<p>270PPSDOT Female Swivel Elbow</p> 	<p>271PPSDOT Swivel Run Tee</p> 	<p>272PPSDOT Swivel Branch Tee</p> 
<p>277PPSDOT FM Swivel Branch Tee</p> 	<p>279PPSDOT 45° Swivel Elbow</p> 	<p>286PPDOT Female Bulkhead</p> 	

C259PPDOT NYLON PLUG

PART NUMBER	A
C259PPDOT-2.5	5/32"
C259PPDOT-4	1/4"
C259PPDOT-6	3/8"
C259PPDOT-8	1/2"
C259PPDOT-10	5/8"
C259PPDOT-12	3/4"



C264PPDOT UNION TEE

PART NUMBER	Tube O.D.	A	B
C264PPDOT-2.5	5/32"	18.3	18.3
C264PPDOT-4	1/4"	20.6	20.6
C264PPDOT-6	3/8"	26.2	26.2
C264PPDOT-664	3/8" x 1/4"	19.3	25.0
C264PPDOT-8	1/2"	28.8	28.8
C264PPDOT-10	5/8"	33.4	33.4

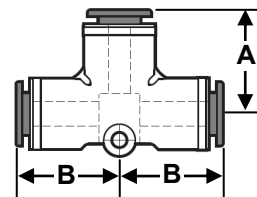

C262PPDOT UNION CONNECTOR

PART NUMBER	Tube O.D.	A
C262PPDOT-2.5	5/32"	32.6
C262PPDOT-4	1/4"	34.6
C262PPDOT-6	3/8"	42.6
C262PPDOT-8	1/2"	44.6
C262PPDOT-10	5/8"	53.4
C262PPDOT-12	3/4"	68.2

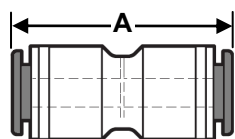

C265PPDOT 90° UNION ELBOW

PART NUMBER	Tube O.D.	A
C265PPDOT-2.5	5/32"	18.3
C265PPDOT-4	1/4"	20.6
C265PPDOT-6	3/8"	26.1
C265PPDOT-8	1/2"	28.9

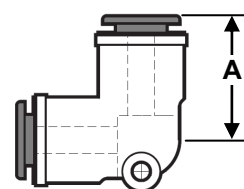

C262PPBHDOT BULKHEAD UNION

PART NUMBER	Tube O.D.	A	HEX	Thread
C262PPBHDOT-2.5	5/32"	32.1	17.46	1/2-20
C262PPBHDOT-4	1/4"	34.1	17.46	9/16-18
C262PPBHDOT-6	3/8"	42.1	25.40	7/8-14
C262PPBHDOT-8	1/2"	44.1	28.57	1-12
C262PPBHDOT-10	5/8"	50.0	33.33	1 1/8-12

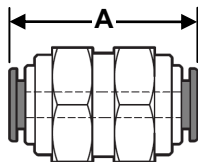

C266PPDOT FEMALE CONNECTOR

PART NUMBER	Tube O.D.	FPT	A	Hex
C266PPDOT-2.5A	5/32"	1/8"	27.0	14.29
C266PPDOT-2.5B	5/32"	1/4"	30.7	17.46
C266PPDOT-4A	1/4"	1/8"	27.5	14.29
C266PPDOT-4B	1/4"	1/4"	31.2	17.46
C266PPDOT-4C	1/4"	3/8"	33.3	22.23
C266PPDOT-6A	3/8"	1/8"	30.8	17.46
C266PPDOT-6B	3/8"	1/4"	34.5	17.46
C266PPDOT-6C	3/8"	3/8"	36.6	22.23
C266PPDOT-6D	3/8"	1/2"	40.6	23.81
C266PPDOT-8A	1/2"	1/8"	31.4	22.23
C266PPDOT-8B	1/2"	1/4"	35.4	22.23
C266PPDOT-8C	1/2"	3/8"	36.4	22.23
C266PPDOT-8D	1/2"	1/2"	40.8	23.80
C266PPDOT-10D	5/8"	1/2"	42.9	25.40

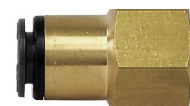
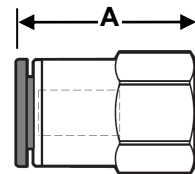

C268PPDOT MALE CONNECTOR

PART NUMBER	Tube O.D.	MPT	A	HEX
C268PPDOT-2.50	5/32"	1/16"	21.7	11.11
C268PPDOT-2.5A	5/32"	1/8"	21.7	11.11
C268PPDOT-4A	1/4"	1/8"	22.2	12.70
C268PPDOT-4B	1/4"	1/4"	22.7	14.29
C268PPDOT-4C	1/4"	3/8"	21.7	17.46
C268PPDOT-4D	1/4"	1/2"	26.0	22.23
C268PPDOT-6A	3/8"	1/8"	30.7	17.46
C268PPDOT-6B	3/8"	1/4"	33.2	17.46
C268PPDOT-6C	3/8"	3/8"	28.7	17.46
C268PPDOT-6D	3/8"	1/2"	26.2	22.23
C268PPDOT-8B	1/2"	1/4"	34.2	22.23
C268PPDOT-8C	1/2"	3/8"	32.7	22.23
C268PPDOT-8D	1/2"	1/2"	29.7	22.23
C268PPDOT-10C	5/8"	3/8"	38.6	25.40
C268PPDOT-10D	5/8"	1/2"	37.9	25.40
C268PPDOT-12C	3/4"	3/8"	47.5	30.0
C268PPDOT-12D	3/4"	1/2"	50.5	30.0
C268PPDOT-12E	3/4"	3/4"	52.5	30.0

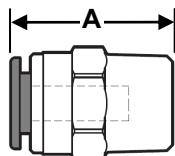

269PPSDOT 90° MALE ELBOW

PART NUMBER	Tube O.D.	MPT	A	B
C269PPSDOT-2.5A	5/32"	1/8"	20.6	23.4
C269PPSDOT-2.5B	5/32"	1/4"	20.6	27.4
C269PPSDOT-4A	1/4"	1/8"	20.6	23.4
C269PPSDOT-4B	1/4"	1/4"	20.6	27.4
C269PPSDOT-4C	1/4"	3/8"	20.6	29.4
C269PPSDOT-4D	1/4"	1/2"	20.6	33.4
C269PPSDOT-6A	3/8"	1/8"	26.2	26.6
C269PPSDOT-6B	3/8"	1/4"	26.2	29.6
C269PPSDOT-6C	3/8"	3/8"	26.2	31.6
C269PPSDOT-6D	3/8"	1/2"	26.2	36.5
C269PPSDOT-8B	1/2"	1/4"	28.8	31.5
C269PPSDOT-8C	1/2"	3/8"	28.8	33.5
C269PPSDOT-8D	1/2"	1/2"	28.8	37.5
C269PPSDOT-8E	1/2"	3/4"	29.0	40.7
C269PPSDOT-10C	5/8"	3/8"	33.4	37.8
C269PPSDOT-10D	5/8"	1/2"	33.4	40.8
C269PPSDOT-10E	5/8"	3/4"	33.4	44.1
C269PPSDOT-12D	3/4"	1/2"	44.1	45.5
C269PPSDOT-12E	3/4"	3/4"	44.1	48.7

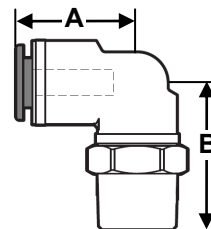

C2688PPDOT PLUG IN

PART NUMBER	Tube O.D.	Cavity	A
C2688PPDOT-4B	1/4"	1/4" SAE	17.9
C2688PPDOT-4D	1/4"	1/2" SAE	17.8
C2688PPDOT-6B	3/8"	1/4" SAE	29.0
C2688PPDOT-6C	3/8"	3/8" SAE	21.5
C2688PPDOT-6D	3/8"	1/2" SAE	21.2
C2688PPDOT-8C	1/2"	3/8" SAE	31.9
C2688PPDOT-8D	1/2"	1/2" SAE	22.4
C2688PPDOT-10D	5/8"	1/2" SAE	35.0

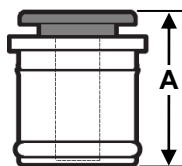

270PPSDOT 90° FEMALE SWIVEL ELBOW

PART NUMBER	Tube O.D.	MPT	A	B
C270PPSDOT-2.5A	5/32"	1/8"	20.6	22.0
C270PPSDOT-2.5B	5/32"	1/4"	20.6	25.5
C270PPSDOT-4A	1/4"	1/8"	20.6	22.0
C270PPSDOT-4B	1/4"	1/4"	20.6	25.5
C270PPSDOT-4C	1/4"	3/8"	20.6	26.0
C270PPSDOT-6A	3/8"	1/8"	26.2	18.8
C270PPSDOT-6B	3/8"	1/4"	26.2	27.7
C270PPSDOT-6C	3/8"	3/8"	26.2	28.2
C270PPSDOT-6D	3/8"	1/2"	26.2	32.2
C270PPSDOT-8B	1/2"	1/4"	28.8	29.6
C270PPSDOT-8C	1/2"	3/8"	28.8	30.1
C270PPSDOT-8D	1/2"	1/2"	28.8	34.1
C270PPSDOT-10D	5/8"	1/2"	33.5	37.5

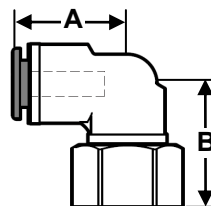

C271PPSDOT MALE SWIVEL RUN TEE

PART NUMBER	Tube O.D.	MPT	A	B	HEX
C271PPSDOT-2.5X	5/32"	1/16"	20.6	44	14.29
C271PPSDOT-2.5A	5/32"	1/8"	20.6	44	14.29
C271PPSDOT-2.5B	5/32"	1/4"	20.6	48	14.29
C271PPSDOT-464	1/4"x3/8"	3/8"	26.2	55.8	19.00
C271PPSDOT-4A	1/4"	1/8"	20.6	44	14.29
C271PPSDOT-4B	1/4"	1/4"	20.6	48	14.29
C271PPSDOT-4C	1/4"	3/8"	20.6	50	17.46
C271PPSDOT-644	3/8"	1/4"	25.7	55.3	19.00
C271PPSDOT-646	3/8"x1/4"	3/8"	25.7	57.7	19.00
C271PPSDOT-6B	3/8"	1/4"	26.2	55.8	19.00
C271PPSDOT-6C	3/8"	3/8"	26.2	57.8	19.00
C271PPSDOT-6D	3/8"	1/2"	26.2	61.8	22.23
C271PPSDOT-866	1/2"x3/8"	3/8"	27.1	58.7	23.80
C271PPSDOT-868	1/2"x3/8"	1/2"	27.1	49.1	22.23
C271PPSDOT-848	1/2"x1/4"	1/2"	26.6	62.2	23.80
C271PPSDOT-8B	1/2"	1/4"	28.8	60.3	19.00
C271PPSDOT-8C	1/2"	3/8"	28.8	62.3	19.00
C271PPSDOT-8D	1/2"	1/2"	28.8	66.3	22.23
C271PPSDOT-10D	5/8"	1/2"	33.5	74.5	23.80

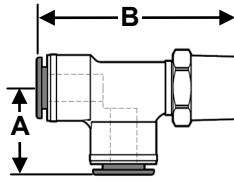

C277PPSDOT FEMALE SWIVEL BRANCH TEE

PART NUMBER	Tube O.D.	FPT	A	B	HEX
C277PPSDOT-4A	1/4"	1/8"	22.0	20.6	14.29
C277PPSDOT-4B	1/4"	1/4"	25.5	20.6	17.46
C277PPSDOT-6A	3/8"	1/8"	19.0	26.0	17.46
C277PPSDOT-6B	3/8"	1/4"	27.7	26.2	17.46
C277PPSDOT-8C	1/2"	3/8"	30.1	28.8	22.23
C277PPSDOT-10B	5/8"	1/4"	25.8	33.4	23.80

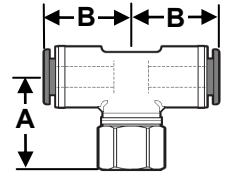

C279PPSDOT 45° MALE ELBOW

PART NUMBER	Tube O.D.	MPT	A	B	HEX
C279PPSDOT-2.5A	5/32"	1/8"	19.0	20.3	14.29
C279PPSDOT-4A	1/4"	1/8"	19.0	20.3	14.29
C279PPSDOT-4B	1/4"	1/4"	19.0	24.3	14.29
C279PPSDOT-4C	1/4"	3/8"	19.0	26.3	17.46
C279PPSDOT-6A	3/8"	1/8"	26.2	26.6	19.00
C279PPSDOT-6B	3/8"	1/4"	26.2	29.6	19.00
C279PPSDOT-6C	3/8"	3/8"	26.2	31.6	19.00
C279PPSDOT-6D	3/8"	1/2"	26.2	35.6	22.23
C279PPSDOT-8A	1/2"	1/8"	28.8	29.5	23.80
C279PPSDOT-8B	1/2"	1/4"	28.8	32.5	23.80
C279PPSDOT-8C	1/2"	3/8"	28.8	33.5	23.80
C279PPSDOT-8D	1/2"	1/2"	28.8	37.5	23.80
C279PPSDOT-10C	5/8"	3/8"	29.6	32.0	23.80
C279PPSDOT-10D	5/8"	1/2"	29.6	35.0	23.80
C279PPSDOT-12D	3/4"	1/2"	39.1	41.9	28.57

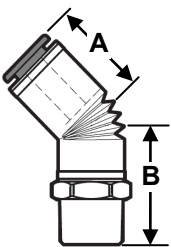

C272PPSDOT MALE SWIVEL RUN TEE

PART NUMBER	Tube O.D.	MPT	A	B	HEX
C272PPSDOT-2.5X	5/32"	1/16"	23.4	41.2	14.29
C272PPSDOT-2.5A	5/32"	1/8"	23.4	41.2	14.29
C272PPSDOT-2.5B	5/32"	1/4"	27.4	41.2	14.29
C272PPSDOT-4A	1/4"	1/8"	23.4	41.2	14.29
C272PPSDOT-4B	1/4"	1/4"	27.4	41.2	14.29
C272PPSDOT-4C	1/4"	3/8"	29.4	41.2	17.46
C272PPSDOT-6A	3/8"	1/8"	26.6	52.4	19.00
C272PPSDOT-6B	3/8"	1/4"	29.6	52.4	19.00
C272PPSDOT-6C	3/8"	3/8"	31.6	54.4	19.00
C272PPSDOT-6D	3/8"	1/2"	35.6	52.4	22.23
C272PPSDOT-8B	1/2"	1/4"	31.5	57.6	19.00
C272PPSDOT-8C	1/2"	3/8"	33.5	57.6	19.00
C272PPSDOT-8D	1/2"	1/2"	37.5	57.6	22.23
C272PPSDOT-10C	5/8"	3/8"	37.8	66.8	23.80
C272PPSDOT-10D	5/8"	1/2"	40.8	66.8	23.80

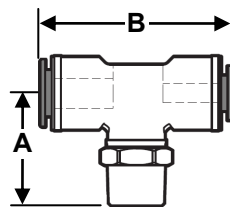

C286PPDOT FEMALE BULKHEAD

PART NUMBER	Tube O.D.	FPT	UNF	A
C286PPDOT-5B	5/32"	1/4"	1/2-20	31.0
C286PPDOT-4A	1/4"	1/8"	9/16-18	27.5
C286PPDOT-4B	1/4"	1/4"	9/16-18	32.4
C286PPDOT-6B	3/8"	1/4"	7/8-14	34.5
C286PPDOT-6C	3/8"	3/8"	7/8-14	36.9
C286PPDOT-8C	1/2"	3/8"	1-12	37.1
C286PPDOT-8D	1/2"	1/2"	1-12	41.2

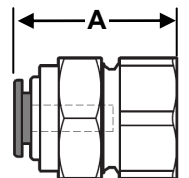



NYLON AIR BRAKE TUBING



CONSTRUCTION

- Type A** tubing consists of a single wall extrusion of pelletized homopolymer or copolymer of polyamide containing additives that provide heat and light resistance.
- Type B** tubing consists of a core extrusion with one or two layers of pelletized polyamide containing additives that provide heat resistance. The core is fiber reinforced using a spiral filament applied in each direction and sheathed with a protective layer of chemical resistant homopolymer or copolymer of polyamide containing additives for heat and light resistance. The cover is fusion bonded to the core tube through the interstices of the spiral yarn reinforcement. The core tube and cover are of contrasting colors.

APPLICATIONS

•NAB150-Series polyamide tubing is for use in air brake systems. Non-reinforced tubing is designated Type A and reinforced tubing Type B. This tubing is intended for brake system connections that maintain a basically fixed relationship between couplings during vehicle operation.

Air Tanks: Stores Air for Braking, Suspension, Sliders, etc.

Air Brake Systems: Chassis (Provide Stopping Power for Truck/Trailer)

Air Brake Systems: Brake Chamber (Provide Stopping Power for Truck/Trailer)

Tire Inflation Systems: Keeps Tires at Optimal Pressure

Air Ride Systems: Provides Air Suspension in Seat, Cab, and Vehicle



RANGES

- 150 psig maximum (1030 KPa)
- 40°F to +200°F (-40°C to +93°C)



Part No.:	Nominal O.D. (In)	Outside Dia. (In)	Inside Dia. (In)	Wall Thickness (In)	Min. Burst Pressure @ 73°F	Min. Bend Radius (In)	Max Stiffness (lbs)
NAB150-2A	1/8"	.128/.122	0.079	.026/.020	1000	0.37	1
NAB150-2.5A	5/32"	.153/.159	0.092	.029/.035	1200	0.5	1
NAB150-3A	3/16"	.185/.191	0.118	.032/.038	1200	0.75	1
NAB150-4A	1/4"	.253/.247	0.17	.043/.037	1200	1	2
NAB150-5A	5/16"	.316/.308	0.232	.044/.036	1000	1.25	6
NAB150-6B	3/8"	.379/.371	0.251	.066/.058	1400	1.5	8
NAB150-8B	1/2"	.505/.495	0.376	.066/.058	950	2	20
NAB150-10B	5/8"	.630/.620	0.441	.097/.087	900	2.5	50
NAB150-12B	3/4"	.755/.745	0.566	.097/.087	800	3	80

COLOR	CODE
BLACK	BK
BLUE	BL
BROWN	BR
GREEN	GR
ORANGE	OR
PURPLE	PR
RED	RD
SILVER	SL
TAN	TN
YELLOW	YL
WHITE	WT

Robo-Fit Example Part No.:	NAB150-6B-500-BK
Product Description:	Nylon Air Brake Tubing, 3/8", Black, Type B, 500' Reel





⚠ WARNING: This product can expose you to chemicals including **Nickel and Nickel Compounds** which is known to the State of California to cause cancer. For more information go to www.P65Warnings.ca.gov



MADE IN USA

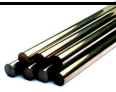

AIR BRAKE HOSE ENDS

CONSTRUCTION	<ul style="list-style-type: none"> • CA360 Brass 
APPLICATIONS	<ul style="list-style-type: none"> • Air Brake Systems 
RANGES	<ul style="list-style-type: none"> • Temperature Range: -40° to 200° F. • Pressure Range: Up to 150 PSI 



Assembly Instructions

1. Slide the nut/spring guard over the J1402 air brake hose.
2. Slide the sleeve over the hose, making sure the tapered edge of the sleeve is facing the fitting body (shown below).
3. Push the hose over the fitting body until the hose bottoms out.
4. Tighten the nut until there is contact with the fitting body's hex. Completed assembly shown below.

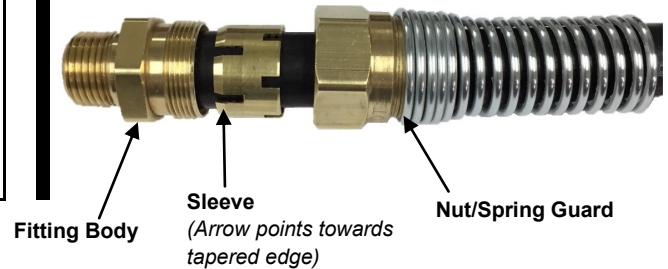

Application Details:

Transportation Air Brake Systems.

Use with J1402 Air Brake Hose



Fully Wrenched Assembly

NOTES

- Fittings meet SAE and DOT FMVSS 571.106
- Non-stock items and special parts are available on a quotation basis.
- Configurations and dimensions are subject to change without notice.

⚠ WARNING: Products offered by Robo-Fit, Inc. can expose you to chemicals such as lead, a chemical which is known to the State of California to cause cancer, birth defects, or other reproductive harm. For more information go to www.P65Warnings.ca.gov

<p>360A Hose Sleeve</p> 	<p>361A Hose Nut</p> 	<p>361AG Spring Guard Nut</p> 
<p>362A Union Hose Splicer</p> 	<p>366A Female Hose Swivel Connector</p> 	<p>368A Male Hose Connector</p> 
<p>370A Hose Nut w/ Spring Guard</p> 	<p>371AS Hose Spring Guard</p> 	<p>378A Hose Connector with Spring</p> 
<p>388A Hose Adapter</p> 		

360A HOSE SLEEVE

PART NUMBER	HOSE	A
360A-6	3/8"	.69
360A-8	1/2"	.69

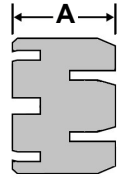

362A UNION HOSE SPLICER

PART NUMBER	HOSE	A
362A-6	3/8"	2.95
362A-8	1/2"	2.96

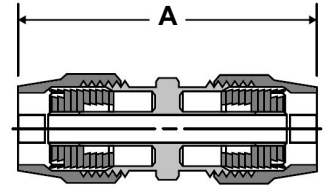

361A HOSE NUT

PART NUMBER	HOSE	A	HEX
361A-6	3/8"	1.18	13/16"
361A-8	1/2"	1.125	1-1/4"

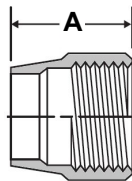

366A FEMALE SWIVEL HOSE CONNECTOR

PART NUMBER	HOSE	THD	A
366A-6C	3/8"	3/4-20	2.30
366A-8D	1/2"	7/8-20	2.36

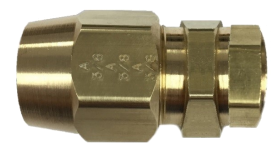
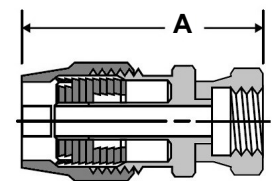

**Use w/ 388A Series*

361AG SPRING GUARD NUT

PART NUMBER	HOSE	A	HEX
361AG-6	3/8"	1.22	1-1/16"
361AG-8	1/2"	1.19	1-1/4"

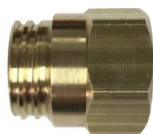
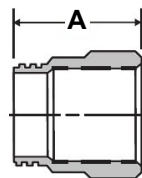

368A MALE HOSE CONNECTOR

PART NUMBER	HOSE	MPT	A	HEX
368A-6B	3/8"	1/4"	2.25	1"
368A-6C	3/8"	3/8"	2.38	1"
368A-6D	3/8"	1/2"	2.44	1"
368A-8C	1/2"	3/8"	2.24	1-1/8"
368A-8D	1/2"	1/2"	2.40	1-1/8"

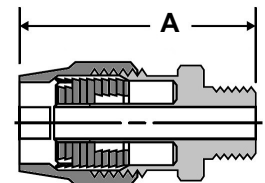

371A HOSE NUT WITH SPRING GUARD

PART NUMBER	HOSE	A	HEX
371A-6	3/8"	3.50	13/16"
371A-8	1/2"	3.75	1-1/4"

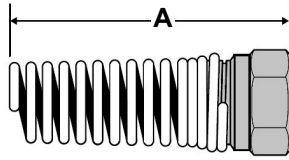

388A HOSE ADAPTER

PART NUMBER	STRAIGHT THREAD	MPT	A	HEX
388A-12B	3/4-20	1/4"	1.06	3/4"
388A-12C	3/4-20	3/8"	1.12	3/4"
388A-14C	7/8-20	3/8"	1.19	7/8"
388A-14D	7/8-20	1/2"	1.38	7/8"

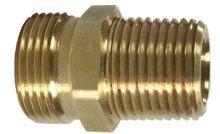
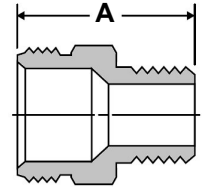

371AS HOSE SPRING GUARD

PART NUMBER	HOSE	A
371AS-6	3/8"	2.75
371AS-8	1/2"	3.00

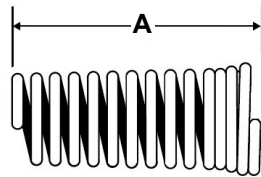



378A HOSE CONNECTOR W/ SPRING GUARD

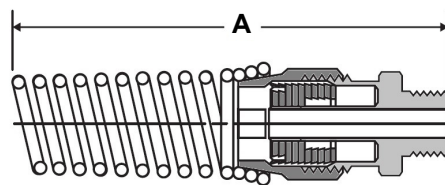

PART NUMBER	HOSE	MPT	A	HEX
378A-6B	3/8"	1/4"	4.75	1"
378A-6C	3/8"	3/8"	4.75	1"
378A-6D	3/8"	1/2"	4.88	1"
378A-8C	1/2"	3/8"	5.12	1-1/8"
378A-8D	1/2"	1/2"	4.88	1-1/8"





DRAIN & TRUCK VALVES

CONSTRUCTION	<ul style="list-style-type: none"> • CA360 Brass • CA377 Brass 
APPLICATIONS	<ul style="list-style-type: none"> • In Line Shut Off • Air Drain • Drain Valves 
RANGES	<ul style="list-style-type: none"> • Maximum Pressure : 30 PSIG • Maximum Pressure: 150 PSI • Temperature: -20° F to +250° F 

	FEATURES/BENEFITS <ul style="list-style-type: none"> • Forged Brass Body • Plug Style Valve • Economical Tight Shut Off • Made in USA 
---	---

NOTES

- Parts that include “PBF” are supplied as low lead compliant. 
- Part numbers without the “PBF” distinction are NOT lead free compliant.
- Non-stock items and special parts are available on a quotation basis.
- Configurations and dimensions are subject to change without notice.

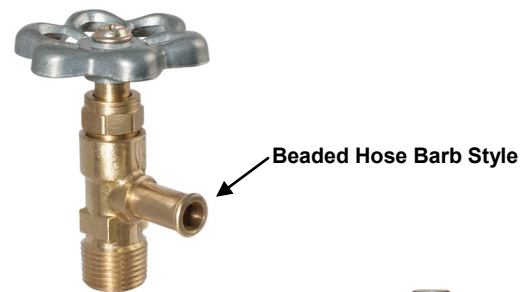

⚠ WARNING: Products offered by Robo-Fit, Inc. can expose you to chemicals such as lead, a chemical which is known to the State of California to cause cancer, birth defects, or other reproductive harm. For more information go to www.P65Warnings.ca.gov

247V MPT INTERNAL SEAT DRAIN VALVE

PART NUMBER	MPT
247V-J	1/8"
247V-L	1/4"
247V-N	3/8"
247V-P	1/2"



H35C SPRING BOTTOM DRAIN VALVE

PART NUMBER	MPT	P.S.I.G.
H35C-J	1/8"	150
H35C-L	1/4"	150

**Valve Shown in "Open" Position*

**Rated 150 P.S.I.G.*



30C SPRING BOTTOM DRAIN VALVE

PART NUMBER	MPT	P.S.I.G.
30C-J	1/8"	30
30C-L	1/4"	30
30C-N	3/8"	30
30C-P	1/2"	30

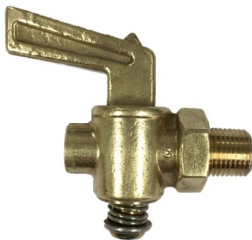

**Valve Shown in "Closed" Position*

**Rated 30 P.S.I.G.*

38D MACHINED DRAIN COCK

PART NUMBER	MPT	FLOW DIA.
38D-DCR	1/4"	.156

**Temperature Range:*

-30° to +250°F

**Rated 150 P.S.I.G.*

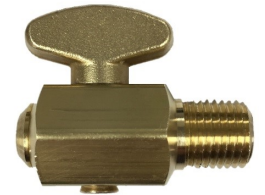

31C SPRING BOTTOM DRAIN VALVE

PART NUMBER	MPT	P.S.I.G.
31C-J	1/8"	30
31C-L	1/4"	30
31C-N	3/8"	30
31C-P	1/2"	30

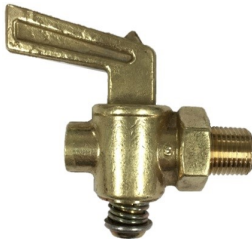

**Valve Shown in "Open" Position*

**Rated 30 P.S.I.G.*

201DH 90° BEADED DRAIN COCK

PART NUMBER	HOSE BIBB	MPT
201DH	3/8"	1/4"



H30C SPRING BOTTOM DRAIN VALVE

PART NUMBER	MPT	P.S.I.G.
H30C-J	1/8"	150
H30C-L	1/4"	150

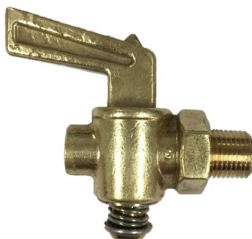

**Valve Shown in "Open" Position*

**Rated 150 P.S.I.G.*

320D EXTERNAL SEAT DRAIN COCK

PART NUMBER	MPT
320D	1/8"
321D	1/4"
322D	3/8"



421D EXTENSION EXTERNAL SEAT DRAIN

PART NUMBER	MPT
421D	1/4"



90V FPT X MPT RISING STEM VALVE

PART NUMBER	SIDE PORT	BOTTOM PORT	HANDLE
90V-N	3/8" FPT	3/8" MPT	ROUND
900V-N	3/8" FPT	3/8" MPT	ROUND
90V-NP	3/8" FPT	1/2" MPT	ROUND
900V-P	1/2" FPT	1/2" MPT	ROUND



97V HOSE TO MPT RISING STEM VALVE

PART NUMBER	SIDE PORT	BOTTOM PORT	HANDLE
P97V-6N	3/8" MLT HOSE	3/8" MPT	PIN
97V-6N	3/8" MLT HOSE	3/8" MPT	ROUND
97V-6N1	3/8" BIB HOSE	3/8" MPT	ROUND
P97V-10N	5/8" BIB HOSE	3/8" MPT	PIN
97V-10N	5/8" BIB HOSE	3/8" MPT	ROUND
97V-10P	5/8" BIB HOSE	1/2" MPT	ROUND
907V-10P	5/8" BIB HOSE	1/2" MPT	ROUND
907V-12N	3/4" BIB HOSE	3/8" MPT	ROUND
907V-12P	3/4" BIB HOSE	1/2" MPT	ROUND



**Pin Handle*



**Round Handle*



**Beaded Hose Barb*



**Beaded Hose Barb*

95V FLARE X MPT RISING STEM VALVE

PART NUMBER	SIDE PORT	BOTTOM PORT	HANDLE
95V-6N	3/8" FLARE	3/8" MPT	ROUND
P95V-6N	3/8" FLARE	3/8" MPT	PIN
95V-10P	5/8" FLARE	1/2" MPT	ROUND
905V-10P	5/8" FLARE	1/2" MPT	ROUND
95V-P10	1/2" MPT	5/8" FLARE	ROUND



**Flare x MPT*



**MPT x Flare*

**Maximum Pressure:*

200 P.S.I.G.

**Temperature Rating:*





-20° to +250° F

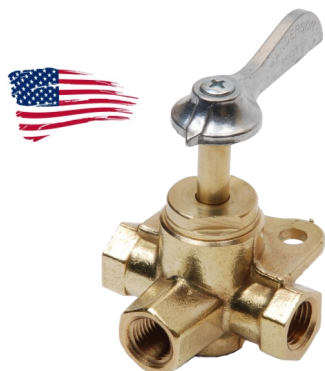

MADE IN USA



SELECTOR VALVES

CONSTRUCTION	• CA377 Brass	
APPLICATIONS	<ul style="list-style-type: none"> • Operation in gasoline, oil, air, water and detergent systems. • Fuel Switching/Tank Selection 	 
RANGES	<ul style="list-style-type: none"> • Maximum Pressure: 30 PSIG on 100/200 • Maximum Pressure: 15 PSIG on SK1036 Temperature: -40°F to +180° F 	



3 & 4-WAY SELECTOR VALVES

The 100 & 200 Series Non-Lubricated Plug Valves are designed to operate in systems where instantaneous port selection is desired. Since lubricants are not used, re-lubrication is not required. There is no lubricant to freeze and lock the valve or to contaminate fine fluids. The o-ring sealed cap and stem eliminate leakage to the atmosphere. The mating

100 SERIES is standard with a pointer lever to indicate the desired porting selection and can be rotated 360°. A number of special body porting patterns, flow combinations, “Click” or “Click-Stop” arrangements and special stem lengths are available. Designed for panel or bracket mounting.

200 SERIES is standard with a pointer lever and an audible “Click Mechanism.” This arrangement assures proper porting selection by sound or touch without looking at the valve. This construction is highly desirable when the operator’s visual attention cannot be distracted or for remote valve locations. The valve rotates 360° with “Click” intervals spaced every 90°. Designed for panel or bracket mounting.

Fluid Port Size	Diameter
1/8" & 1/4"	9/32" (.281)
3/8"	5/16" (.312)

 **WARNING:** Products offered by Robo-Fit, Inc. can expose you to chemicals such as lead, a chemical which is known to the State of California to cause cancer, birth defects, or other reproductive harm. For more information go to www.P65Warnings.ca.gov

THREE-WAY SELECTOR VALVES (SIDE OUTLET)

PART NUMBER	Port Size	Click Stop	# of Ports	Stem Length
210C-J	1/8" FPT	YES	3	1 3/8"
110C-L	1/4" FPT	NO	3	1 3/8"
210C-L	1/4" FPT	YES	3	1 3/8"
210C-LS	1/4" FPT	YES	3	3/4"
210C-LM	1/4" FPT	YES	3	2 3/8"
110C-N	3/8" FPT	NO	3	1 3/8"
210C-N	3/8" FPT	YES	3	1 3/8"

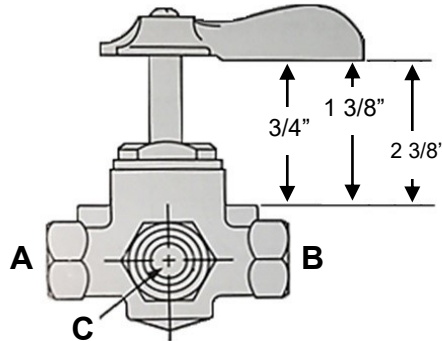

OPENINGS:

- Handle Pointer Over A: Valve Open A-C
- Handle Pointer Over C: Valve Open B-C
- Handle Pointer Over B: Valve "OFF"
- Handle Pointer Over Bracket: Valve "OFF"

FOUR-WAY SELECTOR VALVES

PART NUMBER	Port Size	Click Stop	# of Ports	Stem Length
100C-L	1/4" FPT	NO	4	1 3/8"
200C-L	1/4" FPT	YES	4	1 3/8"
100C-N	3/8" FPT	NO	4	1 3/8"
200C-N	3/8" FPT	YES	4	1 3/8"
205C-L	1/4" FPT	YES	4	2 3/8"
205C-N	3/8" FPT	YES	4	2 3/8"
215C-L	1/4" FPT	YES	4	3 3/4"
115C-N	3/8" FPT	NO	4	3 3/4"
215C-N	3/8" FPT	YES	4	3 3/4"

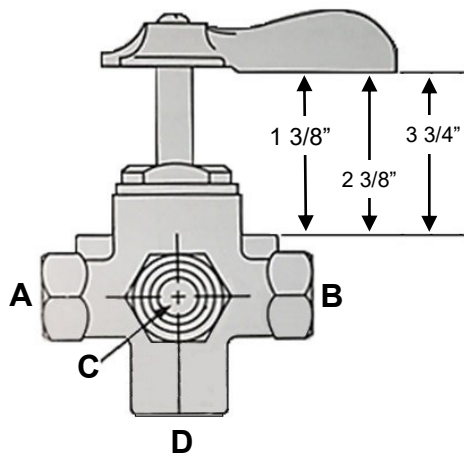

OPENINGS:

- Handle Pointer Over A: Valve Open A-D
- Handle Pointer Over C: Valve Open C-D
- Handle Pointer Over B: Valve Open B-D
- Handle Pointer Over Bracket: Valve "OFF"

SIX PORT VALVES

PART NUMBER	FEMALE PIPE	FEMALE PIPE	LENGTH OF STEM	TYPE
	THREAD	THREAD		
	1-2-3	4-5-6		
SK-1031	1/2"	3/8"	5/16"	1
SK-1036	1/2"	3/8"	13/16"	1
SP-2381-CM	1/2"	3/8"	5/16"	2
SP-2483-CM	1/2"	3/8"	5/16"	3
SP-2486-CM	1/2"	3/8"	13/16"	3

“Designed primarily for diesel engine applications where a fuel return or spill back is required. These valves are widely used in the trucking and marine industry and by manufacturers of diesel generating plants.”

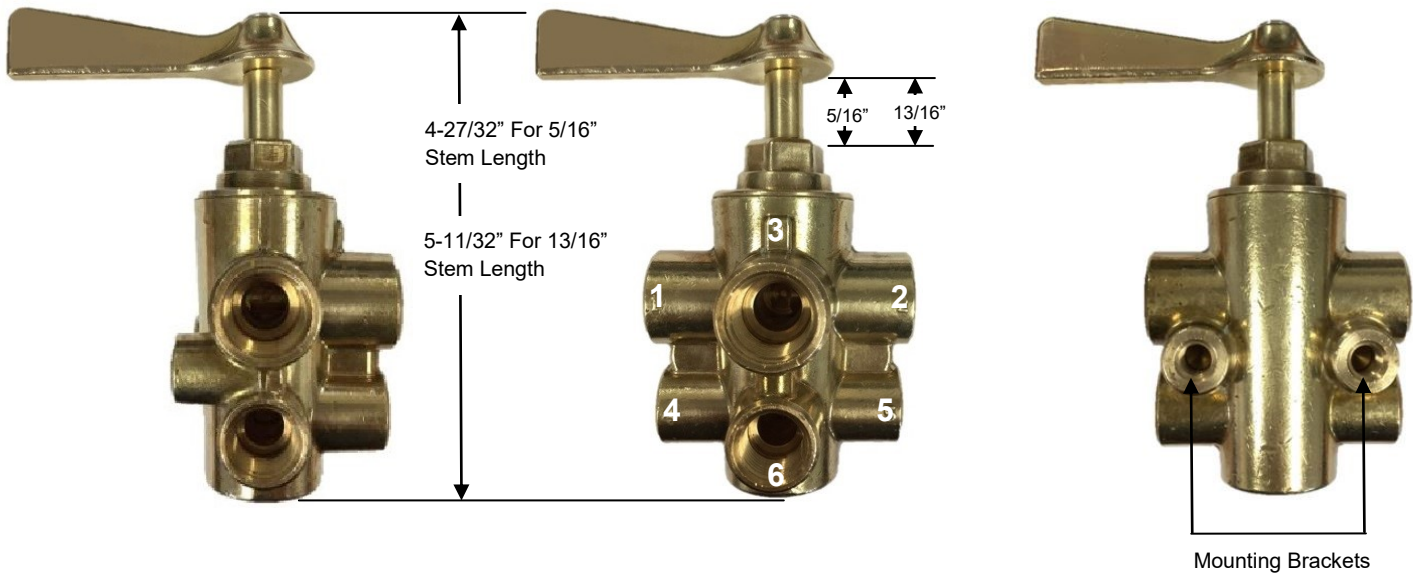



TYPE 1	TYPE 2	TYPE 3
Maximum Handle Travel 180°	Maximum Handle Travel 90°	Maximum Handle Travel 90°
Mounting Pads for Bolt Mounting	Mounting Pads for Bolt Mounting	Mounting Pads for Bolt Mounting
OPENINGS	OPENINGS	OPENINGS
Handle Pointer Over 2: (All Ports Closed)	Handle Pointer Over 3: (Open: 1-3 & 4-6, Closed 2 & 5)	Handle Pointer Over 1: (Open: 1-3 & 4-6, Closed 2 & 5)
Handle Pointer Over 3: (Open: 1-3 & 4-6, Closed 2 & 5)	Handle Pointer Over 2: (Open: 2-3 & 5-6, Closed 1 & 4)	Handle Pointer Over 3: (Open: 2-3 & 5-6, Closed 1 & 4)
Handle Pointer Over 1: (Open: 2-3 & 5-6, Closed 1 & 4)		



MADE IN USA



PANEL MOUNT BALL VALVES

CONSTRUCTION	• CA360 Brass	
APPLICATIONS	• Air Brake Systems	
RANGES	• Temperature Range: -40°F to 300°F -40°C to +93°C • Pressure Range: 1500psig	

	FEATURES/BENEFITS
	<ul style="list-style-type: none"> • Bar-Stock Brass Body • Double O-Ring Stem Seal • 20,000 Leak Free Cycles • Blow Out Proof Stem • Metal Retainer Seal • Made in USA  • Guaranteed Quality

NOTES

- Parts that include “PBF” are supplied as low lead compliant.
- Part numbers without the “PBF” distinction are NOT lead free compliant.
- Non-stock items and special parts are available on a quotation basis.
- Configurations and dimensions are subject to change without notice.



⚠ WARNING: Products offered by Robo-Fit, Inc. can expose you to chemicals such as lead, a chemical which is known to the State of California to cause cancer, birth defects, or other reproductive harm. For more information go to www.P65Warnings.ca.gov

3222BV SERIES 3-WAY BALL VALVES, FPT x FPT x FPT

PART NUMBER	PORT A	PORT B	PORT C	CV	ORIFICE DIA.
3222BV-LLXL	1/4" FPT	1/4" FPT	1/4" FPT	1.57	0.250

**Valves to Read: Left, Right, Middle*

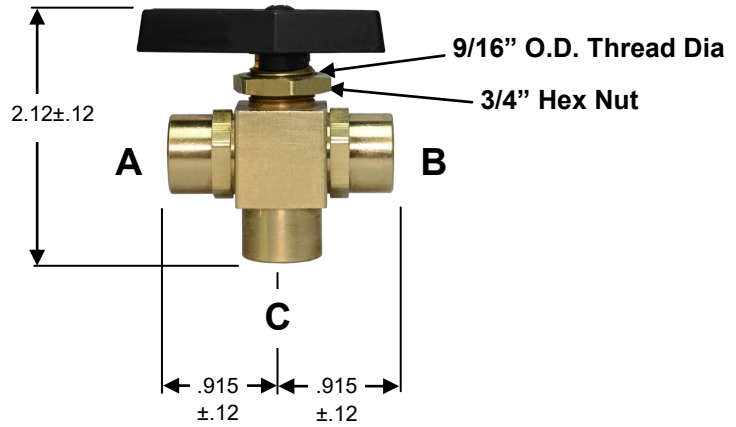

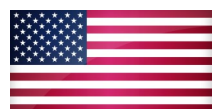
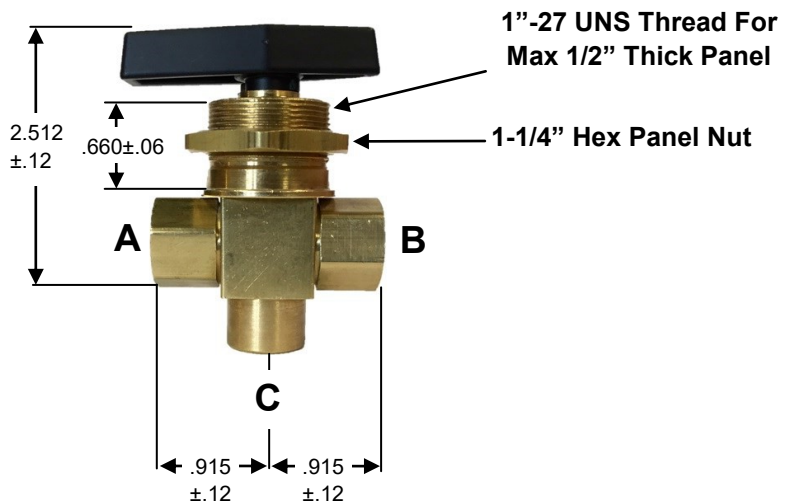

PART NUMBER	PORT A	PORT B	PORT C	CV	ORIFICE DIA.
3222BV-LLXL-8	1/4" FPT	1/4" FPT	1/4" FPT	1.57	0.250





MADE IN USA



INDUSTRIAL BALL VALVES

CONSTRUCTION	<ul style="list-style-type: none"> • CA360 Brass • CA377 Brass 	
APPLICATIONS	<ul style="list-style-type: none"> • Fuel Tank Shut-Off • Coolant Stop • Diverter Valves • Hydraulic or Pneumatic 	
RANGES	<ul style="list-style-type: none"> • Maximum Pressure 600 PSI • Temperature to 300° F • Saturated Steam 150 PSI 	

	FEATURES/BENEFITS
	<ul style="list-style-type: none"> • Forged Brass Body • Double O-Ring Stem Seal • Stem Seal Never Needs Tightening • 20,000 Leak Free Cycles • Blow Out Proof Stem • Made in USA 

NOTES

- Parts that include “PBF” are supplied as low lead compliant. 
- Part numbers without the “PBF” distinction are NOT lead free compliant.
- Non-stock items and special parts are available on a quotation basis.
- Configurations and dimensions are subject to change without notice.



Double o-ring protection provides over 20,000 cycles without leakage!

The exclusive stem seal design that never needs tightening!

 **WARNING:** Products offered by Robo-Fit, Inc. can expose you to chemicals such as lead, a chemical which is known to the State of California to cause cancer, birth defects, or other reproductive harm. For more information go to www.P65Warnings.ca.gov



160BV MALE TO FEMALE BALL VALVE

PART NUMBER	MPT	FPT
160BV-L	3/8"	3/8"
160BV-P	1/2"	1/2"
160BV-R	3/4"	3/4"
160BV-S	1"	1"



120BV 3-WAY FEMALE BALL VALVE

PART NUMBER	FPT	CV
120BV-L	1/4"	5.2
120BV-N	3/8"	5.5
120BV-P	1/2"	5.5



Pressure Rating:

***Bottom Port as Inlet: 500 P.S.I.**

***Side Port as Inlet: 100 P.S.I.**



162BV FEMALE BALL VALVE

PART NUMBER	FPT	FPT
162BV-L	3/8"	3/8"
162BV-P	1/2"	1/2"
162BV-R	3/4"	3/4"
162BV-S	1"	1"

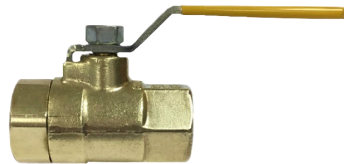

190BV 2-WAY 90° BALL VALVE

PART NUMBER	FPT	MPT	CV
190BV-L	1/4"	1/4"	5.2
190BV-N	3/8"	3/8"	5.5
190BV-P	1/2"	1/2"	5.5



Pressure Rating:

***Bottom Port as Inlet: 600 P.S.I.**



***Side Port as Inlet: 100 P.S.I.**





MADE IN USA



CHECK VALVES

CONSTRUCTION	•CA360 Brass	
APPLICATIONS	•Unidirectional Flow Applications	
RANGES	•Maximum Pressure : 1000 PSIG •Temperature: -40° F to +300° F (Standard) -40° F to +400° F (Special)	

	FEATURES/BENEFITS
	<ul style="list-style-type: none"> •Self Centering Seal Design •O-Ring Soft Seat / Metal Back Up Seat •Zero Leakage •1/3 PSI Cracking Pressure Standard •Optional Cracking Pressures Available •Made in USA  •Guaranteed Quality

NOTES

- Parts that include “PBF” are supplied as low lead compliant.
- Part numbers without the “PBF” distinction are NOT lead free compliant.
- Non-stock items and special parts are available on a quotation basis.
- Configurations and dimensions are subject to change without notice.



⚠ WARNING: Products offered by Robo-Fit, Inc. can expose you to chemicals such as lead, a chemical which is known to the State of California to cause cancer, birth defects, or other reproductive harm. For more information go to www.P65Warnings.ca.gov



Quality Matters!
Our check valves are proudly
Made in America.



741CV MPTF x MPTF

PART NUMBER	MPT	OAL
741CV-J	1/8"	1.20 ± .03



750CV2 FPT x MPT

PART NUMBER	FPT	MPT
750CV2-JXJ	1/8"	1/8"
750CV2-LXL	1/4"	1/4"
750CV2-NXN	3/8"	3/8"
750CV2-PXP	1/2"	1/2"



745CV FLARE x MPTF

PART NUMBER	FLARE	MPTF
745CV-4J	1/4"	1/8"
745CV-J4	1/8"	1/4"



751CV MPT x MPT

PART NUMBER	FPT	FPT
751CV-JXJ	1/8"	1/8"
751CV-LXL	1/4"	1/4"
751CV-NXN	3/8"	3/8"
751CV-PXP	1/2"	1/2"

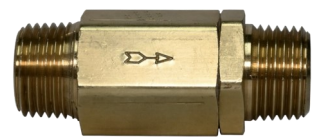

750CV1 MPT x FPT

PART NUMBER	MPT	FPT
750CV1-JXJ	1/8"	1/8"
750CV1-LXL	1/4"	1/4"
750CV1-NXN	3/8"	3/8"
750CV1-PXP	1/2"	1/2"



752CV FPT x FPT

PART NUMBER	MPT	MPT
752CV-JXJ	1/8"	1/8"
752CV-LXL	1/4"	1/4"
752CV-NXN	3/8"	3/8"
752CV-PXP	1/2"	1/2"



750CV Series Flow Direction:



*750CV1: Flows From Male to Female Thread

*750CV2: Flows From Female to Male Thread





MINIATURE BALL VALVES

CONSTRUCTION	<ul style="list-style-type: none"> • CA360 Brass 
APPLICATIONS	<ul style="list-style-type: none"> • In Line Shut-Off • Air Lines • Water Lines ⚠ Not intended for potable water
RANGES	<ul style="list-style-type: none"> • Maximum Pressure : 1000 PSIG • Temperature: -40° F to +300° F (Standard) -40° F to +400° F (Special) 

FEATURES/BENEFITS
<ul style="list-style-type: none"> • Bar-Stock Brass Body • Blow Out Proof Stem • Viton Stem Seal • Standard Lever Handle • Optional Round Handle • Nickel Plated Brass Ball • Made in USA  • Guaranteed Quality

STANDARD LEVER HANDLE

ALTERNATIVE ROUND HANDLE



TO ORDER VALVES WITH THE ROUND HANDLE (SHOWN TO THE RIGHT ABOVE) ADD AN "R" TO THE SERIES PART NUMBER.

EX:
352BV-J: Standard Part Number for Lever Handle
352BVR-J: Special Part Number for Round Handle



350BV FPT x MPT

PART NUMBER	FPT	MPT	CV	ORIFICE
350BV-J	1/8"	1/8"	1.39	.250
350BV-JXL	1/8"	1/4"	1.39	.250
350BV-L	1/4"	1/4"	1.57	.250
350BV-LXN	1/4"	3/8"	1.57	.250

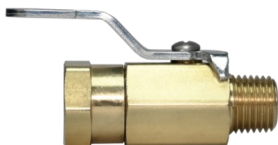

355BV FLARE x MPT

PART NUMBER	FLARE	MPT	CV	ORIFICE
355BV-4J	1/4"	1/8"	1.39	.250
355BV-4L	1/4"	1/4"	1.57	.250
355BV-6J	3/8"	1/8"	1.57	.250
355BV-6L	3/8"	1/4"	1.57	.250
355BV-6N	3/8"	3/8"	2.74	.250

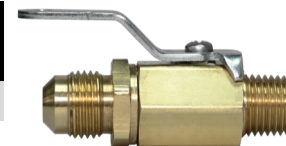

351BV MPT x MPT

PART NUMBER	MPT	MPT	CV	ORIFICE
351BV-J	1/8"	1/8"	1.39	.250
351BV-JXL	1/8"	1/4"	1.39	.250
351BV-L	1/4"	1/4"	1.57	.250
351BV-N	3/8"	3/8"	1.57	.250

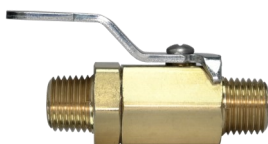

356BV FLARE x FLARE

PART NUMBER	FLARE	CV	ORIFICE
356BV-4	1/4"	1.57	.250
356BV-6	3/8"	1.57	.250

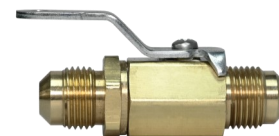

352BV FPT x FPT

PART NUMBER	FPT	FPT	CV	ORIFICE
352BV-J	1/8"	1/8"	1.39	.250
352BV-L	1/4"	1/4"	1.57	.250
352BV-JXL	1/8"	1/4"	1.39	.250

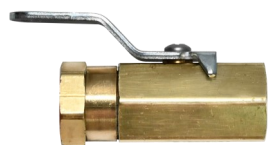

357BV HOSE BARB x FLARE

PART NUMBER	HOSE BARB	MPT	CV	ORIFICE
357BV-4J	1/4"	1/8"	1.39	.250
357BV-4L	1/4"	1/4"	1.57	.250
357BV-5L	5/16"	1/4"	1.57	.250
357BV-6L	3/8"	1/4"	1.57	.250
357BV-6N	3/8"	3/8"	2.74	.250

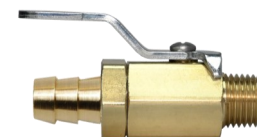

353BV COMPRESSION x MPT

PART NUMBER	O.D. TUBE	MPT	CV	ORIFICE
353BV-4J	1/4"	1/8"	1.39	.250
353BV-4L	1/4"	1/4"	1.57	.250
353BV-6L	3/8"	1/4"	1.57	.250

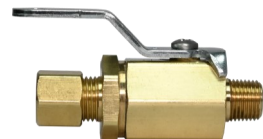

358BV FLARE x FPT

PART NUMBER	FLARE	FPT	CV	ORIFICE
358BV-4J	1/4"	1/8"	1.39	.250
358BV-4L	1/4"	1/4"	1.57	.250

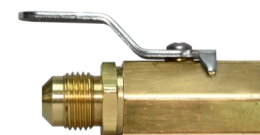

354BV COMPRESSION BOTH ENDS

PART NUMBER	O.D. TUBE	CV	ORIFICE
354BVS-2	1/8"	1.39	.250
354BVS-4	1/8"	1.57	.250
354BVS-6	1/4"	2.74	.250

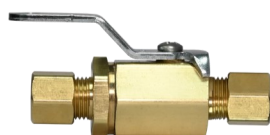

⚠ WARNING: Products offered by Robo-Fit, Inc. can expose you to chemicals such as lead, a chemical which is known to the State of California to cause cancer, birth defects, or other reproductive harm. For more information go to www.P65Warnings.ca.gov

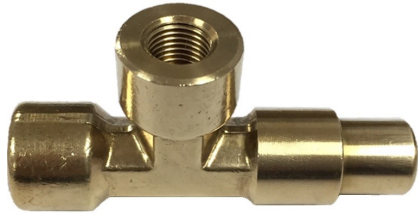

PUSH BUTTON VALVES

CONSTRUCTION

•CA377 Brass



APPLICATIONS

- Fuel Sampling Valve
- Pressure Relief
- Valve Injection
- Drain Valve
- Holds Vacuum

RANGES

- Maximum Pressure : 500 PSIG
- Temperature:
- 40° to 300° F (Standard)
- 40° to 400° F (Special)



FEATURES/BENEFITS

- Instantaneous On/Off
- Multiple O-Ring Options
- Flexible End Connection
- Forged Brass Body
- 90° Configuration
- Made in USA
- Guaranteed Quality



PB2 FPT x FPT

PART NUMBER	FPT	FPT	STYLE	OPERATOR
PB2-J	1/8"	1/8"	STANDARD	PUSH BUTTON
PB2-3A-J	1/8"	1/8"	PANEL MOUNT	PUSH BUTTON
PB2-L	1/4"	1/4"	STANDARD	PUSH BUTTON
PB2-3A-L	1/4"	1/4"	PANEL MOUNT	PUSH BUTTON



WARNING: Products offered by Robo-Fit, Inc. can expose you to chemicals such as lead, a chemical which is known to the State of California to cause cancer, birth defects, or other reproductive harm. For more information go to www.P65Warnings.ca.gov

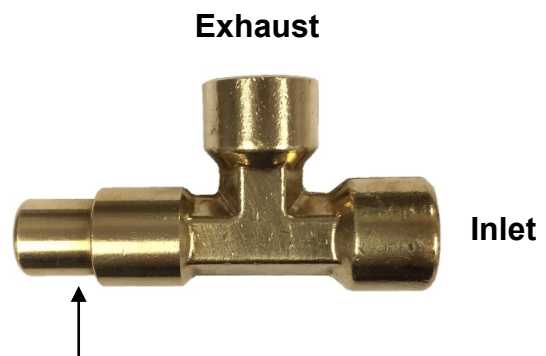

Closed Position Shown



Push Button Toward the Valve Body for Sampling

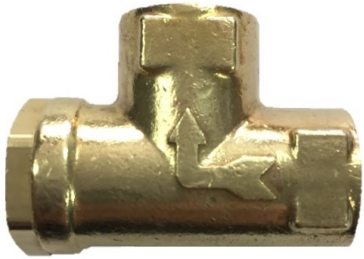

MADE IN USA



STRAINER VALVES

CONSTRUCTION	<ul style="list-style-type: none"> •CA377 Brass •CA360 Brass 	
APPLICATIONS	<ul style="list-style-type: none"> •Filtration •Sediments •Refrigerants 	
RANGES	<ul style="list-style-type: none"> •Maximum Pressure : 500 PSIG •Temperature: <ul style="list-style-type: none"> -40° to 300° F (Standard) -40° to 400° F (Special) 	

FEATURES/BENEFITS
<ul style="list-style-type: none"> •Forged Brass Body •70 x 80 Monel Mesh Screens <ul style="list-style-type: none"> •Viton Seat •Made in USA •Guaranteed Quality



234S STRAINER VALVES

PART NUMBER	THREAD	THREAD
234SJ	1/8" FPT	1/8" FPT
234SL	1/4" FPT	1/4" FPT
234S-4L	1/8" FPT	1/4" MALE FLARE

234SL: Top View

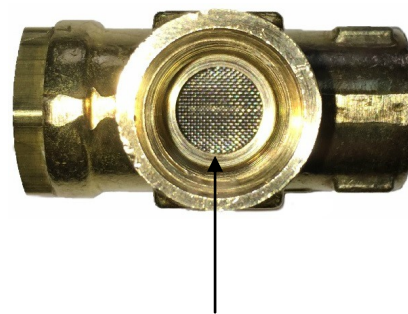

Monel Mesh Screen

⚠ WARNING: Products offered by Robo-Fit, Inc. can expose you to chemicals such as lead, a chemical which is known to the State of California to cause cancer, birth defects, or other reproductive harm. For more information go to www.P65Warnings.ca.gov

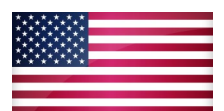

MADE IN USA



ROBO-FIT PRODUCT WARRANTY

Robo-Fit warrants our products to be free of defects in material and workmanship. No warranty of merchantability or other warranty, express or implied is made. Liability for and the exclusive remedy for defective materials or workmanship is limited to the replacement or repair of defective products returned within 30 days after receipt. No allowances will be made for repairs performed by the Purchaser or on their order. Robo-Fit is not liable for consequential or other damages or any expense incurred through the use of its products.

Published literature at the time of initial publication reflects all current design, dimensions and performance data. However, in keeping with our policy of upgrading products on an on-going basis, modifications may result in changes in design, dimensions and/or performance now shown in this catalog. Working pressures and other technical information has been prepared from sources deemed to be reliable but no responsibility can be assumed by Robo-Fit for the accuracy of this information under varied field conditions. It should be considered as a recommendation only and not a guarantee.

 **WARNING:** Products offered by Robo-Fit, Inc. can expose you to chemicals such as lead, a chemical which is known to the State of California to cause cancer, birth defects, or other reproductive harm. For more information go to www.P65Warnings.ca.gov.

As of January 4, 2014, Federal Public Law 111-380 prohibits the sale of plumbing fixtures with a wetted surface area containing more than a weighted average of 0.25% lead. Robo-Fit parts are to be used only for non-potable services, unless they have been given the "PBF" distinction on their corresponding part numbers. It is incumbent upon Robo-Fit customers to determine whether or not the products they use are compliant with Federal Public Law 111-380.



ROBO-FIT, INC.

300 INDUSTRIAL PKWY, CHAGRIN FALLS, OHIO 44022

PHONE (440) 893-9878 • FAX (440) 893-9876

WWW.ROBO-FIT.COM

PIPE THREAD SPECIFICATIONS



National Pipe Thread: NPT & NPTF

NPTF (Dry Seal Pipe Threads)

Dry seal pipe threads are made to the American National Standards Institute (ANSI) B1.20.3 specification and are designed to seal pressure tight joints. NPTF threads are commonly used in fluid power applications.

NPTF thread roots are wider than their crests. When the threads are wrenched together, the roots crush the sharper crest of the mating threads. This thread deformation forms a metal to metal seat, ensuring a leak free connection. To determine the nominal pipe size, measure the thread diameter and subtract 1/4". Use of thread sealant is still recommended to ensure a leak free connection.

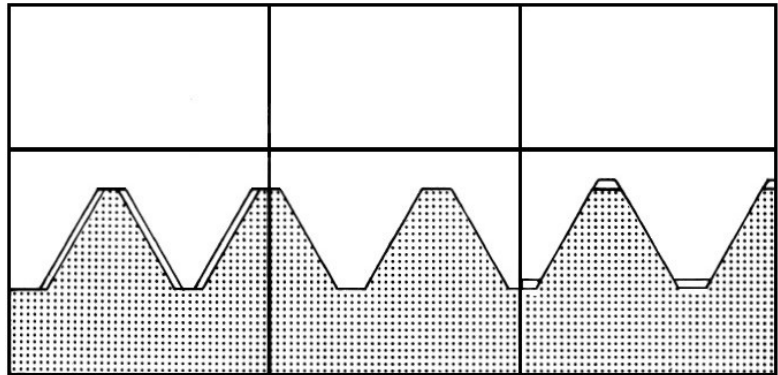

Thread Type	1/8	1/4	3/8	1/2	3/4	1
NPTF	1/8-27	1/4-18	3/8-18	1/2-14	3/4-14	1-11-1/2

NPT (Tapered Pipe Threads)

Non-dry seal pipe threads are made to the American National Standards Institute (ANSI) B1.20.1 specification. NPT threads seal at their respective flanks, leaving the possibility of having clearance between the roots and crests. NPT threads cannot ensure the prevention spiral leakage, and require the use of pipe sealant for all applications. To determine the nominal pipe size, measure the thread diameter and subtract 1/4".

The first two full threads ($\pm 1/2$ THD.) should remain free of pipe sealant to allow for thread engagement when wrenching an assembly.



Ask about our volume vibra-sealing capabilities!

We vibra-seal our fittings in house.

FITTING NUMBERING SYSTEM

O.D. TUBE SIZE

-2	1/8"
-3	3/16"
-4	1/4"
-5	5/16"
-6	3/8"
-7	7/16"
-8	1/2"
-10	5/8"
-12	3/4"
-14	7/8"
-16	1"

PIPE SIZE

-A	1/8"
-B	1/4"
-C	3/8"
-D	1/2"
-E	3/4"
-F	1"

Each part number indicates the style of the fitting and the size, the letters and/or numbers preceding the dash indicate the style and the letters and/or numbers following the dash indicate the size. Fitting part numbers will always read tube to pipe ends.

For example, E1-10D (shown below) is an extruded el-

E1 = 90° Male Flare Elbow

10 = 5/8" O.D.



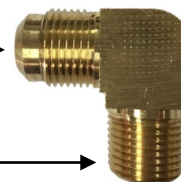









D = 1/2" MPT



STRAIGHT THREAD SIZE CHART

Fitting Type (O.D. Tube Size)	1/8	3/16	1/4	5/16	3/8	7/16	1/2	5/8	3/4	7/8	1
45° Flare	5/16-24	3/8-24	7/16-20	1/2-20	5/18-18	11/16-16	3/4-16	7/8-14	1-1/16-14	1-1/4-12	-
Inverted Flare	5/16-28	3/8-24	7/16-24	1/2-20	5/18-18	11/16-18	3/4-18	7/8-18	1-1/16-16	1-3/16-16	-
Air Brake (DOT)	-	-	7/16-24	-	17/32-24	-	11/16-20	13/16-18	1-18	-	1-1/4-16
Compression (Non DOT)	5/16-24	3/8-24	7/16-24	1/2-24	9/16-24	5/8-24	11/16-20	13/16-18	-	1-1/8-18	1/1/4-18
Poly-Fit	-	-	3/8-24	7/16-24	5/8-24	-	11/16-20	-	1-1/8-18	-	-

FITTING CONFIGURATION NUMBERING SYSTEM

Configuration #	Description	Photo
60	Sleeve	
61	Nut	
62	Union (Tube Both Ends)	
64	Union Tee (Tube All Ends (3))	
65	90° Union Elbow (Tube Both Ends)	
66	Female Connector (Tube to FPT)	
68	Male Connector (Tube to MPT)	
69	90° Male Elbow (Tube to MPT)	
70	90° Female Elbow (Tube to FPT)	
71	Male Run Tee (Tube to MPT to Tube)	
72	Male Branch Tee (Tube to Tube to MPT)	
77	Female Branch Tee (Tube to FPT)	
79	45° Male Elbow (Tube to MPT)	

*71/72/77 Read Left to Right to Branch

WHAT IS PROPOSITON 65?



Proposition 65 requires businesses to provide warnings to Californians about significant exposures to chemicals that cause cancer, birth defects or other reproductive harm. These chemicals can be in the products that Californians purchase, in their homes or workplaces, or that are released into the environment. By requiring that this information be provided, Proposition 65 enables Californians to make informed decisions about their exposures to these chemicals.

Proposition 65 also prohibits California businesses from knowingly discharging significant amounts of listed chemicals into sources of drinking water.

Proposition 65 requires California to publish a list of chemicals known to cause cancer, birth defects or other reproductive harm. This list, which must be updated at least once a year, has grown to include approximately 900 chemicals since it was first published in 1987.

Why is Proposition 65 relevant to Robo-Fit Products?

Some products offered by Robo-Fit can expose you to chemicals such as lead, a chemical which is known to the State of California to cause cancer, birth defects, or other reproductive harm. Robo-Fit parts are to be used only for non-potable services, unless they have been given the "PBF" distinction on their corresponding part numbers.

By law, a warning must be given for listed chemicals unless the exposure is low enough to pose no significant risk of cancer or is significantly below levels observed to cause birth defects or other reproductive harm.

Businesses are required to provide a "clear and reasonable" warning before knowingly and intentionally exposing anyone to a listed chemical, unless the business can show that the anticipated exposure level will not pose a significant risk of cancer or is significantly below levels observed to cause birth defects or other reproductive harm.

This warning can be given in several ways, such as by labeling a consumer product, posting signs at the workplace, distributing notices at a rental housing complex, or publishing notices in a newspaper. The requirement to provide warnings takes effect one year after a chemical is added to the list.

Robo-Fit products will be labeled in the following manner in order to be compliant with Proposition 65:

 **WARNING:** Products offered by Robo-Fit, Inc. can expose you to chemicals such as lead, a chemical which is known to the State of California to cause cancer, birth defects, or other reproductive harm. For more information go to www.P65Warnings.ca.gov.

SAE STANDARDS



J246

Covers complete general and dimensional specifications for tube fittings of the spherical and flanged sleeve compression types for use in the piping of air brake systems on automotive vehicles.

J476

Covers Dryseal American Standard Taper Pipe Thread

J512

Covers complete general and dimensional specifications for the various types of tube fittings intended for general application in the automotive, appliance, and allied fields.

J513

Covers complete general and dimensional specifications for refrigeration tube fittings of the flare type.

J530

Covers complete general and dimensional specifications for those types of pipe fittings commonly used in the automotive and other mass production industries where the use of lubricants or sealers is objectionable.

J531

Covers complete general and dimensional specifications for those types of pipe, filler, and drain plugs commonly used in automotive and related industrial applications.

J844

Covers the minimum requirements for nonmetallic tubing as manufactured for use in air brake systems.

J1131

This SAE Standard is intended to establish uniform methods of testing SAE J844 tubing and fitting assemblies as used in automotive air brake systems.

J1615

This SAE Recommended Practice is intended as a guide to assist designers and/or users in the selection and application of various types of thread sealants.

J2494

Covers general and dimensional specifications for brass bodied reusable Push to Connect tube fittings for use in the piping of vehicular air brake systems.

*Reference listings to SAE products will meet functional requirements; construction may differ from specification.

For further detail consult SAE handbook or <http://www.sae.org/>



PIPE THREAD ASSEMBLY

Straight Fittings:

1. Hand Tighten
2. 1/8" to 1/2": Wrench Tight 2 Full 360° Turns
1/2" & Above: 1 1/2" Full Turns

Shaped Fittings:

1. Hand Tighten
2. Wrench Tight 1" to 1 1/2" Full 360° Turns



**For NPTF Pipe Threads with Pre-Applied Sealant*



PUSH-LOK FITTING ASSEMBLY

1. Make a clean square cut on your hose end.
2. Use lubricant on the end of the hose.
3. Move the fitting into the hose so only one barb is inserted into the hose. Make sure the fitting is lined up properly with the hose.
4. Push the fitting fully into the hose so that the end of the hose is covered by the yellow plastic cap. Make sure the fitting is fully inserted before use.



NYLON AIR BRAKE COMPRESSION END ASSEMBLY

1. Cut tubing squarely—using a tube cutter.
2. Make sure all fittings involved in the assembly are clean of burrs and debris.
3. Insert nylon air brake tubing firmly into the fitting until it bottoms out.
4. Tighten nut according to the chart listed below:

Tube Size	Turns Past Hand-Tight
3/16	2.5
1/4	3
3/8 + 1/2	4
5/8 + 3/4	3.5



DOT PUSH TO CONNECT NYLON AIR BRAKE COMPRESSION END ASSEMBLY

To Connect Fitting & Tubing:

1. Cut tubing squarely—using a tube cutter.
2. Make sure all fittings involved in the assembly are clean of burrs and debris.
3. Insert the nylon air brake tubing past the O-Ring until the tubing bottoms out against the tube stop.
4. Check your connection by pulling on the tubing to ensure tubing is fully inserted.



To Disconnect Fitting & Tubing:

1. Press and hold the collet against the fitting body.
2. Pull the tubing out of fitting.



AIR BRAKE HOSE END ASSEMBLY

1. Slide the nut/spring guard over the J1402 air brake hose.
2. Slide the sleeve over the hose, making sure the tapered edge of the sleeve is facing the fitting body (shown below).
3. Push the hose over the fitting body until the hose bottoms out.
4. Tighten the nut until there is contact with the fitting body's hex.

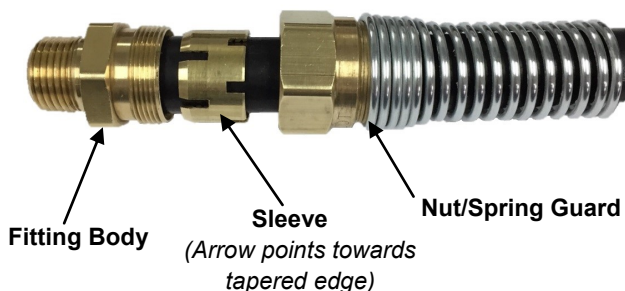

Working pressures and other technical information has been prepared from sources deemed to be reliable but no responsibility can be assumed by Robo-Fit, Inc. for the accuracy of this information under varied field conditions. It should be considered as a recommendation only and not a guarantee.

QUALITY CONTROL

One of Robo-Fit's goals is to supply our customers the highest quality product available. In pursuit of that goal, we have invested in an Image Dimension Measurement System, the "New Standard" for the Manufacturing Industry.

FAST

- No time consuming positioning work or datum setup required
- Measure up to 99 dimensions on up to 100 parts with the push of a button
- Automatically saves measurement data and creates inspection reports

CONSISTENT

- Automatically identifies measurement points, ensuring that the same measurement results are obtained each time
- Automatic focal adjustment prevents inconsistent values
- The simple place-and-press operation means consistent measurement results regardless of the operator

EASY

- Easily set up measurements with just a few clicks
- Setting up virtual lines and points is just as simple
- Automatically saves measurement data and creates inspection reports



Handheld XRF Analyzer

What's in Your Brass??

Knowing the material composition of your brass products is important. Most brass suppliers use material certificates from the brass mills to certify the chemical composition of their products. At Robo-Fit, we assume the mantra of "trust but verify."

X-ray fluorescence involves sophisticated physics, this process can be summarized as (i) X-rays out, (ii) X-rays back, (iii) fancy math, (iv) answer. The instrument can be used to determine the composition of nearly any type of sample.



ROBO-FIT, INC.

300 INDUSTRIAL PKWY, CHAGRIN FALLS, OHIO 44022

PHONE (440) 893-9878 • FAX (440) 893-9876

WWW.ROBO-FIT.COM



*"Making Connections Like Family,
Because That's Who We Are"*